

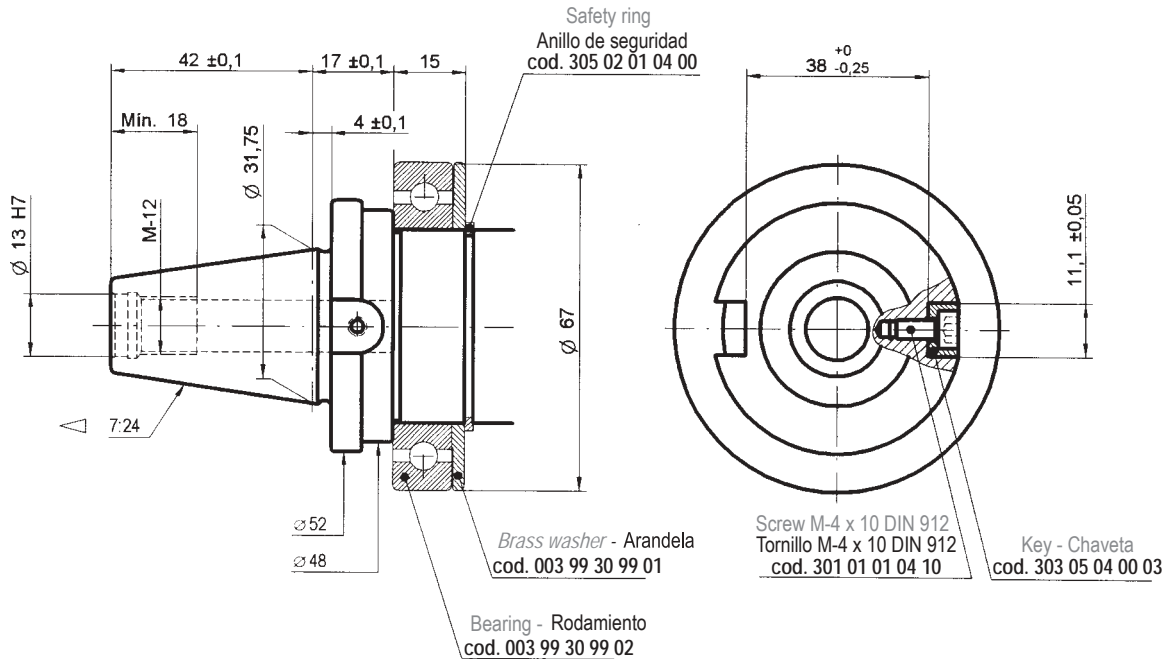

CHIRON
CHIRON

8



FORM B - FORMA B

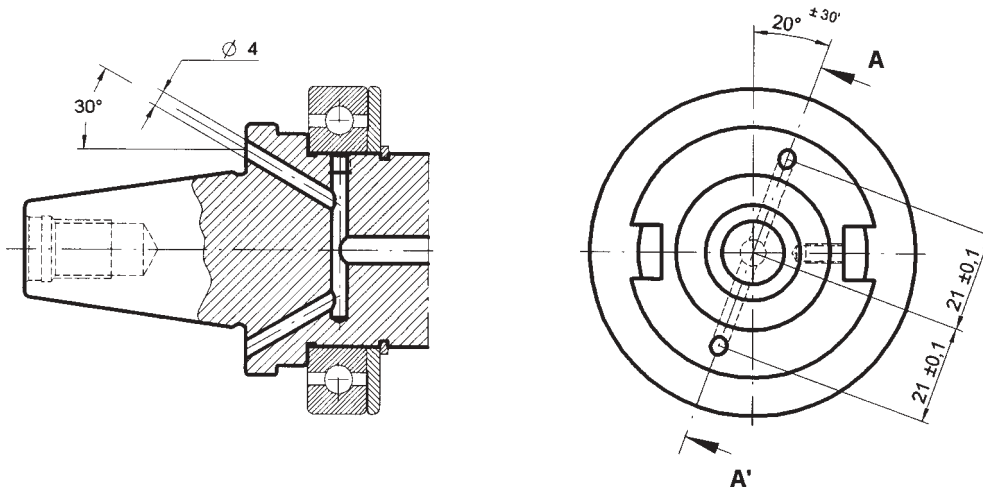

Material:

Case-hardening alloy steel.
Case-hardened and tempered.
Minimum strength in core 880 N/mm^2 .
Surface hardness $\text{Rc } 57 \div 60$

Taper tolerance: Grade AT3.

Material:

Acero aleado de cementación.
Cementado y templado.
Resistencia mínima en el núcleo 880 N/mm^2 .
Dureza superficial $\text{Rc } 57 \div 60$

Tolerancia de conicidad: Calidad AT3.

DYNAMIC BALANCING - EQUILBRADO DINAMICO

- WE HAVE THE LATEST METHODS FOR DYNAMIC BALANCING OF OUR TOOLHOLDERS.
- PLEASE CONTACT US FOR FURTHER INFORMATION.

- CONTAMOS CON MODERNOS MEDIOS PARA EL EQUILBRADO DINÁMICO DE NUESTROS PORTAHERRAMIENTAS.
- INDIQUENOS SUS NECESIDADES.

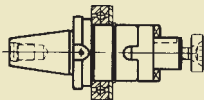
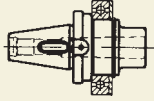
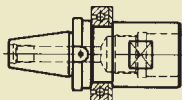
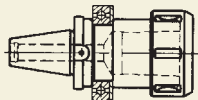
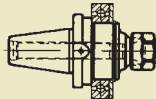
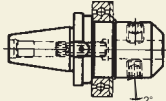
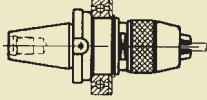
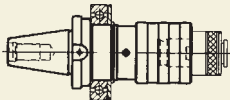
DESCRIPTION DENOMINACION	<i>Page Pag.</i>
UNIVERSAL ARBORS PORTAFRESAS COMBINADO	 8/4
REDUCING ADAPTERS For tanged Morse taper tools DIN 228-B or Morse taper tools with thread DIN 228-A REDUCTORES A MORSE Para herramientas con lengüeta o rosca	 8/5
BASIC ADAPTERS FOR MODULAR TOOLING ADAPTADOR PARA UTILLAJE MODULAR	 8/6
COLLET CHUCKS FOR DIN 6388 COLLETS PORTAPINZAS DIN 6388	 8/7
COLLET CHUCKS ER TYPE (DIN 6499) PORTAPINZAS DIN 6499 (TIPO ER)	 8/8
WELDON AND WHISTLE-NOTCH HOLDERS PORTAFRESAS WELDON Y/O WHISTLE NOTCH	 8/9
SHORT DRILL CHUCKS PORTABROCAS INTEGRAL	 8/10
QUICK-CHANGE TAPPING CHUCKS With self feed and compression system. For BILZ system tap adapter PORTAMACHOS DE CAMBIO RÁPIDO. Tipo BILZ	 8/11

TYPE TIPO	TOOL Ø HERRAMIENTA	LENGTH LONGITUD
30	16 - 27	M

Alternative solutions *003 30 54 + 001 54 0₅³ pgs. 8/6 and 9/3*
Soluciones alternativas



For milling cutters with longitudinal or tenon drive DIN 138
Para fresas con chavetero longitudinal o transversal DIN 138

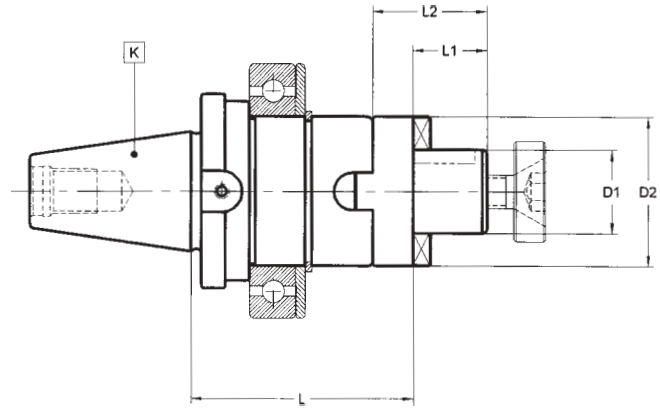

Maximum circular deviation between K and D₁ ≤ 0,008
Desviación circular máxima entre K y D₁ ≤ 0,008

K	D ₁ h6	LENGTH - LONGITUD		L ₁	L ₂	D ₂	COD.
		L					
30	16	60		17	27	32	001 30 02 01 30
30	22	60		19	31	40	001 30 02 01 40
30	27	60		21	33	48	001 30 02 01 50

Accessories, see pages 16/3 - 16/11
Accesorios ver págs 16/3 - 16/11

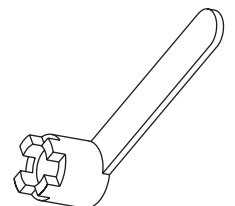
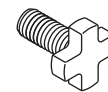
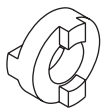

OPTIONS - OPCIONALES

D ₁						
16	001 99 02 01 30	001 99 01 22 30	001 99 01 12 30	001 99 03 02 30	001 99 01 01 30	001 99 04 01 30
22	001 99 02 01 40	001 99 01 22 40	001 99 01 12 40	001 99 03 02 40	001 99 01 01 40	001 99 04 01 40
27	001 99 02 01 50	001 99 01 22 50	001 99 01 12 50	001 99 03 02 50	001 99 01 01 50	001 99 04 01 50

TYPE	TIPO	TYPE	TIPO	LENGTH	LONGITUD
	30	M1 - M3		M	

For tanged Morse taper tools DIN 228-B or Morse taper tools with thread DIN 228-A
Para herramientas con lengüeta DIN 228-B o rosca de tiro DIN 228-A

Alternative solutions *003 30 54 + 003 54 12 pgs. 8/6 and 9/6*
Soluciones alternativas

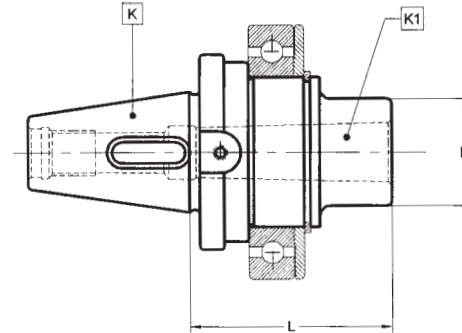

See page 15/10 - Ver pág 15 /10

Maximum circular deviation between K and $K_1 \leq 0,008$
Desviación circular máxima entre K y $K_1 \leq 0,008$

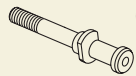
K	K_1	LENGTH - LONGITUD L	D	COD. Forma AD	 (*)
30	1	50	25	003 30 12 01 20	003 99 30 01 20
30	2	62	32	003 30 12 01 30	003 99 30 01 30
30	3	80	40	003 30 12 01 40	003 99 30 01 40

(*) Pull stud for tools with tightening thread



(*) Tirante necesario para utilizar herramientas con rosca de tiro DIN 228-A

TYPE TIPO	OUTSIDE Ø EXTERIOR	LENGTH LONGITUD
30	46	M

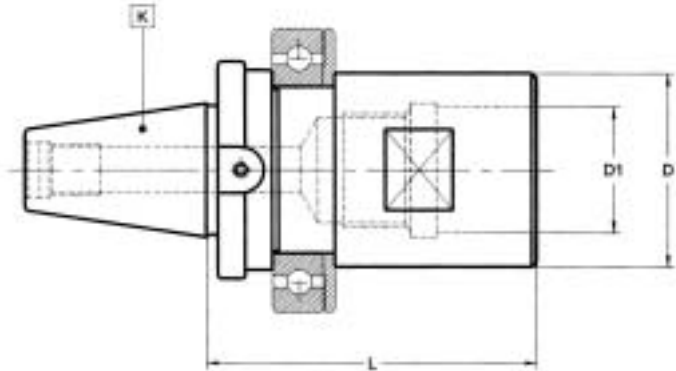
Interchangeable with C.O. system
Intercambiable con el sistema C.O.



Maximum circular deviation between K and D₁ ≤ 0,005
Desviación circular máxima entre K y D₁ ≤ 0,005

K	D ₁ H5	D	LENGTH - LONGITUD L	L ₁	COD.			
30	30	46	80	48	003 30 54 01 06	351 30 00 01 01	001 99 03 01 55	305 02 01 03 20

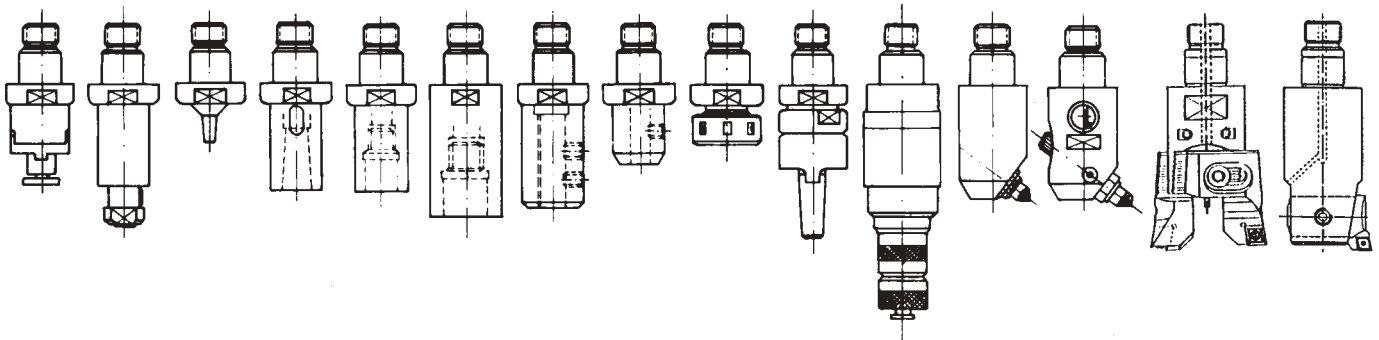
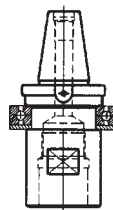

See pages 9/12 - 9/21 - Ver págs 9/12 - 9/21

TYPE TIPO	Ø max	LENGTH LONGITUD
30	25	M

For tools with cylindrical straight shank DIN 1835-A or threaded cylindrical shank DIN 1835-D
Para herramientas con mango cilíndrico liso DIN 1835-A o cilíndrico roscado DIN 1835-D

Alternative solutions 004 30 06 pag. 8/8
Soluciones alternativas 003 30 54 + 004 54 06 pag. 8/6 and 9/10

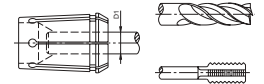
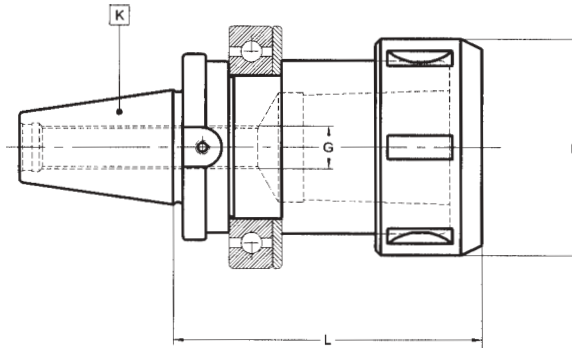

002 01 ...

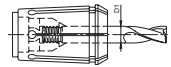

002 03 ...

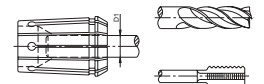

002 04 ...

Collets see pages 14/3 - 14/4
Pinzas ver págs 14/3 - 14/4

Maximum circular deviation between outer taper and collet housing $\leq 0,003$
Desviación circular máxima entre el cono exterior e interior $\leq 0,003$

K	D ₁ máx.	LENGTH - LONGITUD L	D	G	COD.			
30	25	99	60	M-12	004 30 01 01 05	351 30 00 01 01	001 99 03 01 55	305 02 01 03 20

Accessories, see pages 16/3 - 16/11 - Accesorios ver págs 16/3 - 16/11

BALANCED NUT
TUERCA EQUILIBRADA
(STANDARD - ESTÁNDAR)

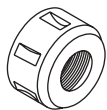

D₁ max.
25

004 99 01 01 05

BEARING NUT
TUERCA GIRATORIA
(OPTIONAL - OPCIONAL)



004 99 01 02 05

WRENCH
LLAVE
(OPTIONAL - OPCIONAL)

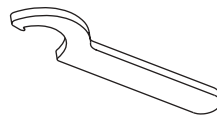

004 99 04 09 11

OPTIONAL - OPCIONAL

- 1 - LENGTH ADJUSTMENT SCREW
- 2 and 3 - LENGTH ADJUSTMENT SCREW WITH THROUGH HOLE
- 1 - TORNILLO DE REGULACION
- 2 y 3 - TORNILLO DE REGULACION CON ORIFICO PARA PASO DE REFRIGERANTE



G	1	2	3
M-12	301 99 02 12 01	301 99 02 12 02	—

TYPE TIPO	SIZE TAMAÑO	LENGTH LONGITUD
30	ER25-ER32	M

For tools with cylindrical straight shank DIN 1835-A
Para herramientas con mango cilíndrico liso DIN 1835-A

Alternative solutions 004 30 01 pag. 8/7
Soluciones alternativas 003 30 54 + 004 54 06 pag. 8/6 and 9/10

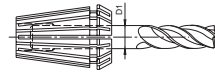
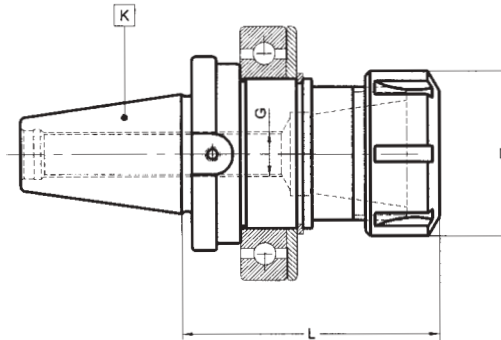

002 11 ...

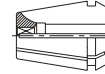

002 14 ...

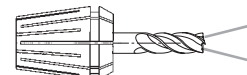

002 15 ...

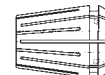

002 16 ...

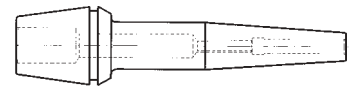

012 62 12 ...

Collets see pages 14/5 - 14/7
Pinzas ver págs 14/5 - 14/7

Maximum circular deviation between K and $D_1 \leq 0,005$
Desviación circular máxima entre el cono exterior e interior $\leq 0,003$

K	SIZE TAMAÑO	D_1 máx.	LENGTH - LONGITUD L	D	G	COD.
30	(ER-25)	16	75	42	M-12	004 30 06 01 05
30	(ER-32)	20	80	50	M-12	004 30 06 01 06

For collets sets see page 14/3.
Composición de diferentes juegos de pinzas, ver pág. 14/3.

Accessories, see pages 16/3 - 16/11
Accesorios ver págs 16/3 - 16/11

OPTIONAL - OPCIONAL

- 1 - LENGTH ADJUSTMENT SCREW
- 2 - LENGTH ADJUSTMENT SCREW WITH THROUGH HOLE
- 1 - TORNILLO DE REGULACION
- 2 - TORNILLO DE REGULACION CON ORIFICIO PARA PASO DE REFRIGERANTE

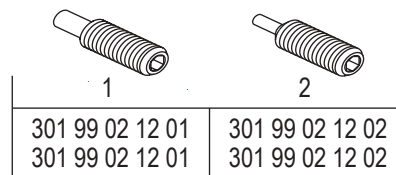

BALANCED NUT TUERCA EQUILIBRADA (STANDARD - ESTÁNDAR)



SIZE - TAMAÑO

ER 25 004 99 01 03 05
ER 32 004 99 01 03 06

BEARING NUT TUERCA GIRATORIA (OPTIONAL - OPCIONAL)



004 99 01 04 05
004 99 01 04 06

WRENCH LLAVE (OPTIONAL - OPCIONAL)

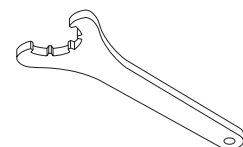

004 99 04 03 05
004 99 04 03 06



TYPE TIPO	TOOL Ø HERRAMIENTA	LENGTH LONGITUD
30	6 - 20	M

For end mills with shank DIN 1835-B and / or DIN 1835-E
Para fresas con mango cilíndrico con encaste DIN 1835 Forma B y/o plano inclinado DIN 1835-Forma E

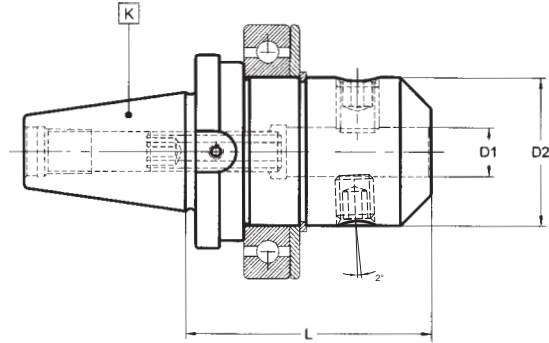
Alternative solutions 003 30 54 + 012 54 04 pgs. 8/6 and 9/8
Soluciones alternativas



Maximum circular deviation between outer taper and collet housing $\leq 0,003$
Maximum circular deviation between K and $D_1 \leq 0,003$

K	D_1	* tol.	LENGTH - LONGITUD		D_2	COD.		
			L					
30	6	+0,007 0	60		25	012 30 04 11 06	301 02 70 05 01	301 01 05 06 10
30	8		60		28	012 30 04 11 08	301 02 70 06 01	301 01 05 08 10
30	10		65		35	012 30 04 11 10	301 02 70 08 01	301 01 05 10 12
30	12		65		40	012 30 04 11 12	301 02 70 10 01	301 01 05 12 16
30	14		65		40	012 30 04 11 14	301 02 70 10 01	301 01 05 12 16
30	16		70		40	012 30 04 11 16	301 02 70 12 01	301 01 05 14 16
30	18	+0,007 0	70		40	012 30 04 11 18	301 02 70 12 01	301 01 05 14 16
30	20		70		40	012 30 04 11 20	301 02 70 12 01	301 01 05 16 16

* The hole diameter and circular deviation tolerances have been significantly tightened up compared with DIN 1835 in order to achieve the highest levels of machining precision.

* Para un mejor rendimiento, hemos restringido considerablemente las tolerancias que para el diámetro D_1 y la excentricidad establece la norma DIN 1835.

TYPE TIPO	TOOL Ø HERRAMIENTA	LENGTH LONGITUD
30	0 - 8	M

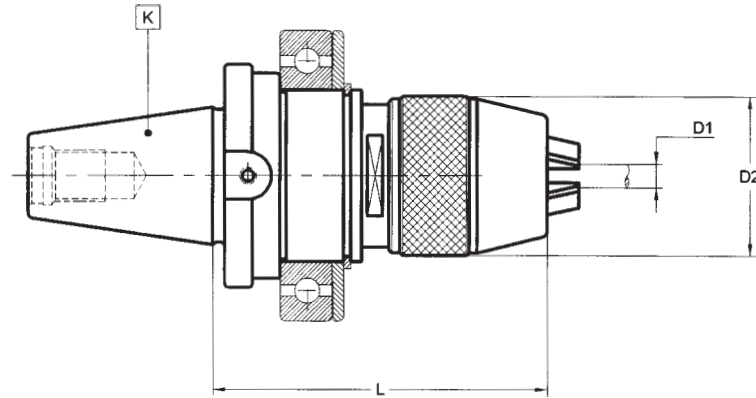

K	D ₁	LENGTH - LONGITUD L	D ₂	COD.			
30	0-8	87	36	012 30 09 11 08	351 02 60 00 08	351 02 61 00 08	020 99 03 00 08

TYPE TIPO	CAP.	LENGTH LONGITUD
30	M3 - M30	M

With self feed and compression system. For BILZ system tap adapter
Doble compensación axial. Para adaptadores sistema BILZ.

Alternative solutions 012 30 04 + 019 55 52 pgs . 8/9 and 13/4
Soluciones alternativas

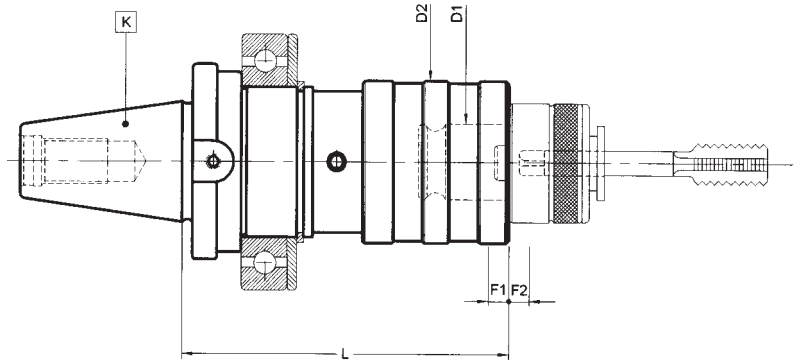

BILZ Adapter
Acoplamiento tipo BILZ

K	CAP.	D ₁	LENGTH - LONGITUD L	D ₂	F ₁	F ₂	COD. Forma A
30	M3-M12 (M-16)*	19	77	36	7,5	7,5	019 30 52 01 02
30	M8-M20 (M-30)*	31	87	53	12,5	12,5	019 30 52 01 03

F₁ Compression run
F₂ Extension run

F₁ Recorrido de compresión
F₂ Recorrido de extensión

* With 002 22 and 002 24 adapters

* Con adaptadores 002 22 y 002 24

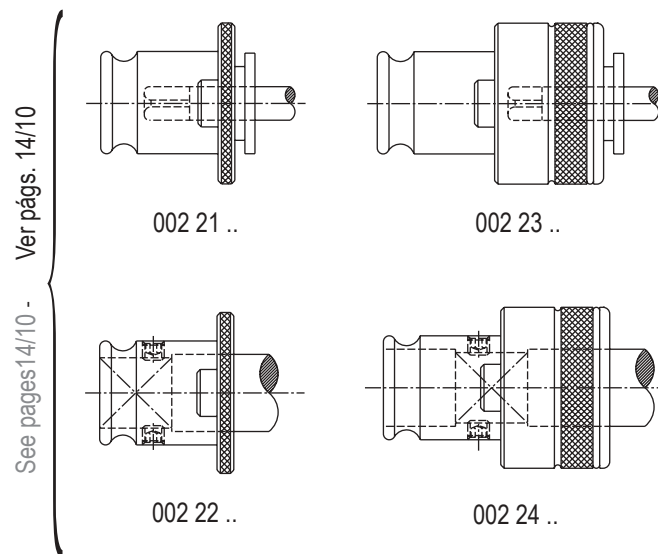

D ₁	OPTIONAL - OPCIONAL			
19	002 21 02	002 22 02	002 23 02	002 24 02
31	002 21 03	002 22 03	002 23 03	002 24 03