

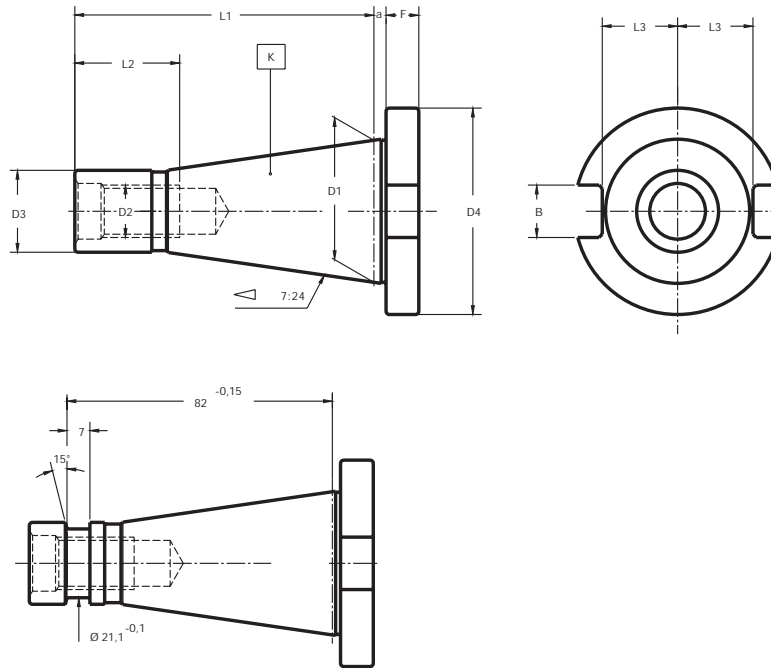

DIN 2080
DIN 2080

6



"DIN 2080 - 40"
With MAHO-OTT ring (see page 15/3)
Con ranura MAHO-OTT (ver pag15/3)

Material:
Case-hardening alloy steel.
Case-hardened and tempered.
Minimum strength in core 880 N/mm².
Surface hardness Rc 57 ÷ 60

Taper tolerance: Grade AT3.

Material:
Acero aleado de cementación.
Cementado y templado.
Resistencia mínima en el núcleo 880 N/mm².
Dureza superficial Rc 57 ÷ 60

Tolerancia de conicidad: Calidad AT3.

K	B H12	D ₁	D ₂	D ₃	D ₄ ⁺⁰ / _{-0,4}	L ₁	L ₂	L ₃ máx	a ^{±0,2}	F ^{±0,15}
30	16,1	31,75	M-12	17,11	50	68,4	24	16,2	1,6	8
(*) 40	16,1	44,45	M-16	25	63	93,4	32	22,5	1,6	10
45	19,3	57,15	M-20	32,09	80	106,8	40	29	3,2	12
50	25,7	69,85	M-24	39,29	97,5	126,8	47	35,3	3,2	12

DYNAMIC BALANCING - EQUILIBRADO DINAMICO

- WE HAVE THE LATEST METHODS FOR DYNAMIC BALANCING OF OUR TOOLHOLDERS (see page 17/2).
- PLEASE CONTACT US FOR FURTHER INFORMATION.

- CONTAMOS CON MODERNOS MEDIOS PARA EL EQUILIBRADO DINÁMICO DE NUESTROS PORTAHERRAMIENTAS (ver pág. 17/2)
- INDIQUENOS SUS NECESIDADES.

DESCRIPTION DENOMINACION	Page Pag.	DESCRIPTION DENOMINACION	Page Pag.
STUB ARBORS PORTAFRESAS CON CHAVETA LONGITUDINAL	6/4	REDUCING ADAPTERS With double effect pull stud For tools with taper DIN 2080 REDUCTORES A ISO Con tirante de doble efecto	6/19
UNIVERSAL ARBORS PORTAFRESAS COMBINADO	6/5	BASIC ADAPTERS FOR MODULAR TOOLING ADAPTADORES PARA UTILLAJE MODULAR	6/20
CENTERING PLUG ARBORS CENTRADORES	6/6	COLLET CHUCKS FOR DIN 6388 COLLETS PORTAPINZAS DIN 6388	6/21
SHELL END MILL ARBORS PORTAFRESAS CON CHAVETAS FRONTALES	6/7	GREAT POWER COLLET CHUCKS PORTAPINZAS DE GRAN APRIETE	6/22 6/23
LONG MILLING MACHINE ARBORS ÁRBOLES PORTAFRESAS LARGOS	6/8	COLLET CHUCKS ER TYPE (DIN 6499) PORTAPINZAS DIN 6499 (TIPO ER)	6/24
DRILL CHUCK ARBORS ADAPTADORES PARA PORTABROCAS	6/9	COLLET CHUCKS ER TYPE (DIN 6499) PORTAPINZAS DIN 6499 (TIPO ER)	6/25
DOUBLE CONTACT SHELL END MILLARBORS EJES PORTAFRESAS DE DOBLE APOYO	6/10	QUICK-CHANGE HOLDER PORTABROCAS DE CAMBIO RÁPIDO	6/26 6/27
DIRECT COUPLING COLLETS ISO DIN 2080 Taper PINZAS DE ACOPLAMIENTO DIRECTO Cono ISO DIN 2080	6/11	QUICK-CHANGE ADAPTERS ADAPTADORES PARA PORTABROCAS DE CAMBIO RÁPIDO	7/15 ...21
REDUCING ADAPTERS For Morse taper tools with thread DIN 228-A REDUCTORES A MORSE Para herramientas con rosca	6/12	END MILL HOLDERS PORTAFRESAS WELDON	6/28
REDUCING ADAPTERS For Morse taper tools with thread DIN 228-A REDUCTORES A MORSE Para herramientas con rosca	6/13	SHORT DRILL CHUCKS PORTABROCAS INTEGRAL	6/29 6/30
REDUCING ADAPTERS For Morse taper tools with thread DIN 228-A REDUCTORES A MORSE Para herramientas con rosca	6/14	TAPPING CHUCKS Self feed and compression system PORTAMACHOS Doble compensación axial y escape	6/31
REDUCING ADAPTERS For Morse taper tools with thread DIN 228-A REDUCTORES Y PROLONGADORES A MORSE Para herramientas con lengüeta o rosca	6/15	QUICK-CHANGE TAPPING CHUCKS Self feed and compression system PORTAMACHOS DE CAMBIO RÁPIDO Doble compensación axial y escape	6/32
LONG REDUCING ADAPTERS For tapered Morse taper tools DIN 228-B REDUCTORES A MORSE LARGOS Para herramientas con lengüeta	6/16	QUICK-CHANGE TAPPING CHUCKS For BILZ system tap adapter PORTAMACHOS DE CAMBIO RÁPIDO Tipo BILZ	6/33
HOLDERS FOR ADJUSTABLE ADAPTERS DIN 6327 ADAPTADORES PARA HERRAMIENTAS DIN 6327	6/17	TOOLHOLDER BLANKS PORTAHERRAMIENTAS SEMIACABADOS	6/34
REDUCING ADAPTERS For tools with DIN 2080, DIN 69871 or MAS-BT taper REDUCTORES A ISO	6/18		

TYPE TIPO	TOOL Ø HERRAMIENTA	LENGTH LONGITUD
30, 40, 50	10 - 50	M

For milling cutters with longitudinal drive DIN 138
Para fresas con chavetero longitudinal o transversal DIN 138

DIN 6360

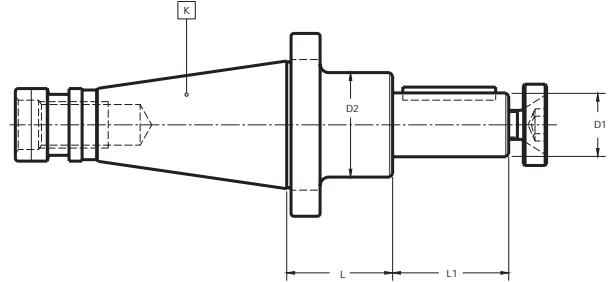

Maximum circular deviation between K and $D_1 \leq 0,008$
Desviación circular máxima entre K y $D_1 \leq 0,008$

K	D_1 h6	LENGTH - LONGITUD L	L_1	D_2	COD.
30	10	35	16	20	001 05 01 01 10
30	13	35	25	23	001 05 01 01 20
30	16	35	30	28	001 05 01 01 30
30	22	35	40	36	001 05 01 01 40
30	27	35	60	43	001 05 01 01 50
40	16	37	30	28	001 05 01 02 30
40	22	37	40	36	001 05 01 02 40
40	27	37	60	43	001 05 01 02 50
40	32	37	60	48	001 05 01 02 60
40	40	37	60	56	001 05 01 02 70
50	16	40	30	28	001 05 01 04 30
50	22	40	40	36	001 05 01 04 40
50	27	40	60	43	001 05 01 04 50
50	32	40	60	48	001 05 01 04 60
50	40	40	60	56	001 05 01 04 70
50	50	40	60	70	001 05 01 04 80

Accessories, see pages 16/3 - 16/11
Accesorios ver págs. 16/3 - 16/11

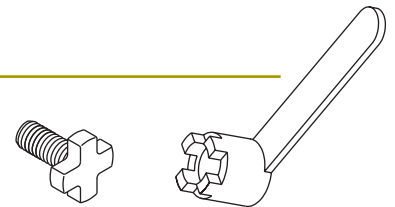
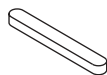

D_1			
10	-	001 99 01 01 10	001 99 03 01 10
13	001 99 01 22 20	001 99 01 12 20	001 99 03 01 20
16	001 99 01 22 30	001 99 01 12 30	001 99 03 01 30
22	001 99 01 22 40	001 99 01 12 40	001 99 03 01 40
27	001 99 01 22 50	001 99 01 12 50	001 99 03 01 50
32	001 99 01 22 60	001 99 01 12 60	001 99 03 01 60
40	001 99 01 22 70	001 99 01 12 70	001 99 03 01 70
50	001 99 01 22 80	001 99 01 12 80	001 99 03 01 80

OPTIONALS - OPCIONALES	
001 99 01 01 20	001 99 04 01 20
001 99 01 01 30	001 99 04 01 30
001 99 01 01 40	001 99 04 01 40
001 99 01 01 50	001 99 04 01 50
001 99 01 01 60	001 99 04 01 60
001 99 01 01 70	001 99 04 01 70
001 99 01 01 80	001 99 04 01 80

TYPE TIPO	TOOL Ø HERRAMIENTA	LENGTH LONGITUD
30, 40, 50	16 - 50	M

Alternative solutions 003 05 54 + 001 54 0³/₅ pgs. 6/20 y 9/3
Soluciones alternativas

For milling cutters with longitudinal or tenon drive DIN 138
Para fresas con chavetero longitudinal o transversal DIN 138

DIN 6358

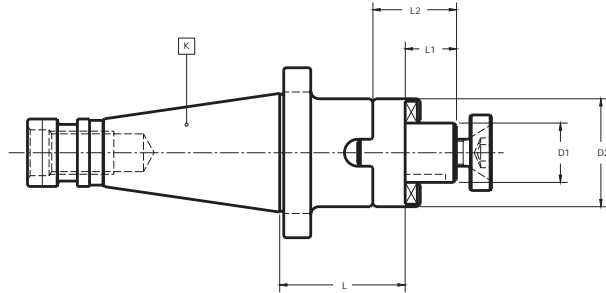

Maximum circular deviation between K and D₁ ≤ 0,008
Desviación circular máxima entre K y D₁ ≤ 0,008

K	D ₁ h6	LENGTH - LONGITUD		L ₁	L ₂	D ₂	COD.
		L					
30	16	35		17	27	32	001 05 02 01 30
30	22	35		19	31	40	001 05 02 01 40
30	27	35		21	33	48	001 05 02 01 50
30	32	50		24	38	58	001 05 02 01 60
40	16	52		17	27	32	001 05 02 02 30
40	22	52		19	31	40	001 05 02 02 40
40	27	52		21	33	48	001 05 02 02 50
40	32	52		24	38	58	001 05 02 02 60
40	40	52		27	41	70	001 05 02 02 70
50	16	55		17	27	32	001 05 02 04 30
50	22	55		19	31	40	001 05 02 04 40
50	27	55		21	33	48	001 05 02 04 50
50	32	55		24	38	58	001 05 02 04 60
50	40	55		27	41	70	001 05 02 04 70
50	50	55		30	46	90	001 05 02 04 80

Accessories, see pages 16/3 - 16/11
Accesorios ver págs. 16/3 - 16/11

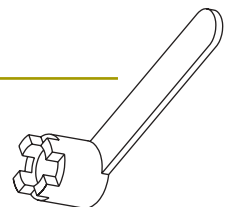
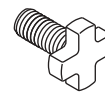
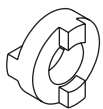

D ₁				OPTIONALS - OPCIONALES		
16	001 99 02 01 30	001 99 01 22 30	001 99 01 12 30	001 99 03 02 30	001 99 01 01 30	001 99 04 01 30
22	001 99 02 01 40	001 99 01 22 40	001 99 01 12 40	001 99 03 02 40	001 99 01 01 40	001 99 04 01 40
27	001 99 02 01 50	001 99 01 22 50	001 99 01 12 50	001 99 03 02 50	001 99 01 01 50	001 99 04 01 50
32	001 99 02 01 60	001 99 01 22 60	001 99 01 12 60	001 99 03 02 60	001 99 01 01 60	001 99 04 01 60
40	001 99 02 01 70	001 99 01 22 70	001 99 01 12 70	001 99 03 02 70	001 99 01 01 70	001 99 04 01 70
50	001 99 02 01 80	001 99 01 22 80	001 99 01 12 80	001 99 03 02 80	001 99 01 01 80	001 99 04 01 80

TYPE TIPO
40, 50, 60

TOOL Ø HERRAMIENTA
40 - 60

For face milling cutters with four holes
Para fresas con cuatro agujeros de fijación

DIN 6356

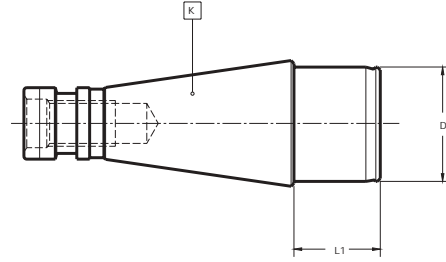

Maximum circular deviation between K and $D_1 \leq 0,008$
Desviación circular máxima entre K y $D_1 \leq 0,008$

K	D_1 g5	L_1	COD.
40	40	30	001 05 04 02 70
50	40	30	001 05 04 04 70
50	50	30	001 05 04 04 80
50	60	40	001 05 04 04 90
60	50	30	001 05 04 06 80
60	60	40	001 05 04 06 90

TYPE TIPO
40, 50, 60

TOOL Ø HERRAMIENTA
16 - 60

LENGTH LONGITUD
M

Alternative solutions
Soluciones alternativas

001 05 02 pg. 6/5
001 08 0³/₅ pg. 6/10
003 05 54 + 001 54 0³/₅ pgs. 6/20 y 9/3

For shell end mills with driving slot DIN 138
Para fresas con chavetero transversal DIN 138

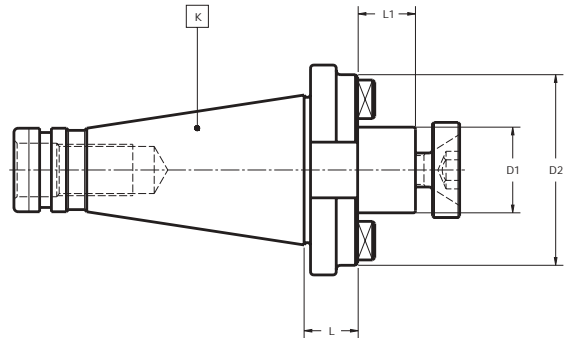
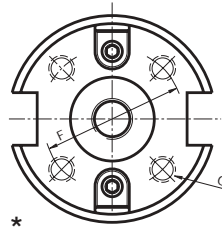

Maximum circular deviation between K and D₁ ≤ 0,008
Desviación circular máxima entre K y D₁ ≤ 0,008

K	D ₁ h6	LENGTH - LONGITUD		L ₁	G	D ₂	F	COD.
		L						
40	16	20		17	—	40	—	001 05 05 02 30
40	22	20		19	—	50	—	001 05 05 02 40
40	27	20		21	—	63	—	001 05 05 02 50
40	32	20		24	—	70	—	001 05 05 02 60
* 40	40	20		27	M-12	89	66,7	001 05 03 02 70
50	22	25		19	—	50	—	001 05 05 04 40
50	27	25		21	—	60	—	001 05 05 04 50
50	32	25		24	—	70	—	001 05 05 04 60
* 50	40	33		27	M-12	89	66,7	001 05 03 04 70
* 50	50	60		30	M-16	129	101,6	001 05 03 04 80
50	50	25		30	—	98	—	001 05 05 04 80
* 50	60	29		40	M-16	129	101,6	001 05 03 04 90
* 60	50	73		30	M-16	129	101,6	001 05 03 06 80

* With additional 4 tapped holes for front clamping according to DIN 2079.
* Con 4 agujeros roscados según DIN 2079 para sujeción de la herramienta.

Accessories, see pages 16/3 - 16/11
Accesorios ver págs. 16/3 - 16/11

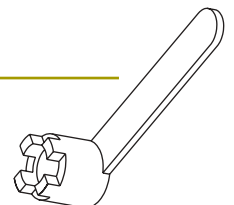
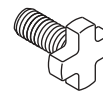

D ₁				
16	303 05 05 00 30	301 01 00 03 15	001 99 01 22 30	001 99 01 12 30
22	303 05 05 00 40	301 01 01 04 12	001 99 01 22 40	001 99 01 12 40
27	303 05 05 00 50	301 01 01 05 12	001 99 01 22 50	001 99 01 12 50
32	303 05 05 00 60	301 01 01 05 16	001 99 01 22 60	001 99 01 12 60
40	003 99 01 01 01	301 01 01 06 16	001 99 01 22 70	001 99 01 12 70
50	303 05 05 00 80	301 01 01 06 20	001 99 01 22 80	001 99 01 12 80
60	303 05 04 00 02	301 01 01 12 25	—	—

OPTIONALS - OPCIONALES

001 99 01 01 30	001 99 04 01 30
001 99 01 01 40	001 99 04 01 40
001 99 01 01 50	001 99 04 01 50
001 99 01 01 60	001 99 04 01 60
001 99 01 01 70	001 99 04 01 70
001 99 01 01 80	001 99 04 01 80
—	—

TYPE TIPO	TOOL Ø HERRAMIENTA
30 - 40 - 50	16 - 60

DIN 6354 - 55

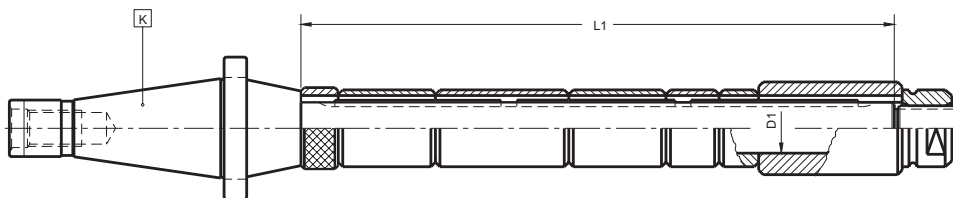

K	D ₁ h6	L ₁	COD.	K	D ₁ h6	L ₁	COD.
30	16	200	001 05 25 01 30	40	32	315	001 05 25 02 62
30	16	250	001 05 25 01 31	40	32	400	001 05 25 02 63
30	16	315	001 05 25 01 32	40	32	500	001 05 25 02 64
				40	32	630	001 05 25 02 65
30	22	200	001 05 25 01 40				
30	22	250	001 05 25 01 41	40	40	315	001 05 25 02 72
30	22	315	001 05 25 01 42	40	40	400	001 05 25 02 73
30	22	400	001 05 25 01 43	40	40	500	001 05 25 02 74
				40	40	630	001 05 25 02 75
30	27	200	001 05 25 01 50				
30	27	250	001 05 25 01 51	50	22	400	001 05 25 04 43
30	27	315	001 05 25 01 52	50	22	500	001 05 25 04 44
30	27	400	001 05 25 01 53				
30	32	200	001 05 25 01 60	50	27	400	001 05 25 04 53
30	32	250	001 05 25 01 61	50	27	500	001 05 25 04 54
30	32	315	001 05 25 01 62	50	27	630	001 05 25 04 55
30	32	400	001 05 25 01 63				
40	16	250	001 05 25 02 31	50	32	400	001 05 25 04 63
40	16	315	001 05 25 02 32	50	32	500	001 05 25 04 64
				50	32	630	001 05 25 04 65
				50	32	800	001 05 25 04 66
40	22	250	001 05 25 02 41				
40	22	315	001 05 25 02 42	50	40	400	001 05 25 04 73
40	22	400	001 05 25 02 43	50	40	500	001 05 25 04 74
40	22	500	001 05 25 02 44	50	40	630	001 05 25 04 75
				50	40	800	001 05 25 04 76
40	27	250	001 05 25 02 51	50	50	400	001 05 25 04 83
40	27	315	001 05 25 02 52	50	50	500	001 05 25 04 84
40	27	400	001 05 25 02 53	50	50	630	001 05 25 04 85
40	27	500	001 05 25 02 54	50	50	800	001 05 25 04 86

Accessories, see pages 16/3 - 16/11
Accesorios ver págs. 16/3 - 16/11

COMPOSITION - COMPOSICION

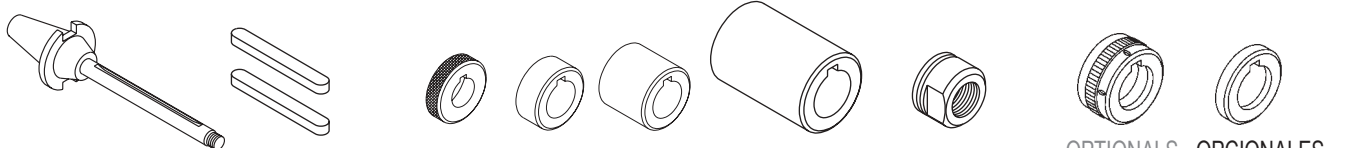

FORMA	001 05 25 ...	001 99 06 ...	001 99 05 ...	001 99 09 ...	001 99 08 ...	001 99 07 ...	001 99 10 ...	001 99 19 ...
A	x	x	x	-	-	x	-	-
B	x	x	x	x	-	x	-	-
C	x	x	x	x	x	x	-	-
D	x	x	x	x	(2) x	x	-	-

TYPE TIPO	TOOL Ø HERRAMIENTA	LENGTH LONGITUD
30, 40, 50	B12 - B18 - J2 - J6	M

Alternative solutions
Soluciones alternativas

003 05 54 + 001 54 50 pgs. 6/20 y 9/4

For DIN 238 or JACOBS
Con alojamiento DIN 238 ó JACOBS

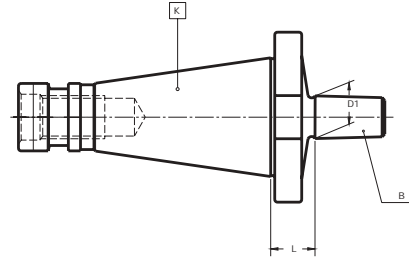

Maximum circular deviation between K and $D_1 \leq 0,008$
Desviación circular máxima entre K y $D_1 \leq 0,008$

K	B - J	LENGTH - LONGITUD L	D_1	COD.
30	B.12	15	12,06	001 05 50 01 01
30	B.16	15	15,73	001 05 50 01 02
40	B.12	17	12,06	001 05 50 02 01
40	B.16	17	15,73	001 05 50 02 02
40	B.18	17	17,78	001 05 50 02 03
50	B.16	20	15,73	001 05 50 04 02
50	B.18	20	17,78	001 05 50 04 03
30	J. 2	15	14,19	001 05 50 01 13
30	J. 3	17	20,59	001 05 50 01 15
30	J. 6	15	17,17	001 05 50 01 18
40	J. 1	22	9,75	001 05 50 02 12
40	J. 2	17	14,19	001 05 50 02 13
40	J.33	17	15,85	001 05 50 02 19
50	J. 2	24	14,19	001 05 50 04 13
50	J. 3	25	20,59	001 05 50 04 15
50	J. 6	20	17,17	001 05 50 04 18

TYPE TIPO	TOOL Ø HERRAMIENTA	LENGTH LONGITUD
40, 50	32 - 50	M

Patent 305.318. For shell end milling cutters with tenon drive DIN 138
Patente 305.318. Para fresas y platos con chavetero transversal

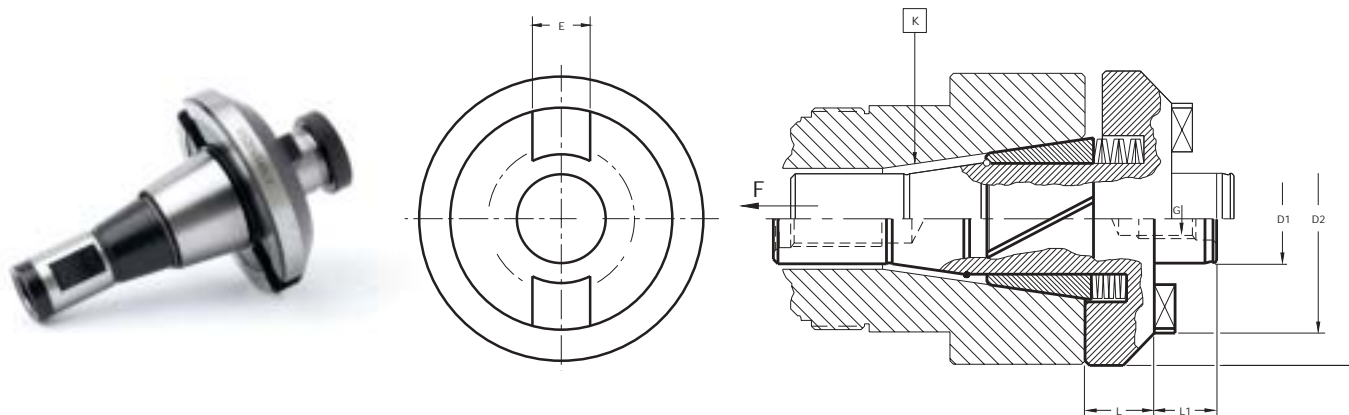

Maximum circular deviation between K and D₁ ≤ 0,008
Desviación circular máxima entre K y D₁ ≤ 0,008

K	D ₁ h5	LENGTH - LONGITUD L	L ₁	D ₂	D	E	G	COD.
40	32	20	24	88	88	14	M-16	001 08 05 02 60
50	27	25	21	68	98	12	M-12	001 08 05 04 50
50	32	25	24	84	98	14	M-16	001 08 05 04 60
50	50	30	30	100	128	18	—	001 08 05 04 80

Accessories, see pages 16/3 - 16/11
Accesorios ver págs. 16/3 - 16/11

D₁

27	001 99 01 22 50	001 99 01 12 50	001 99 01 01 50	001 99 04 01 50
32	001 99 01 22 60	001 99 01 12 60	001 99 01 01 60	001 99 04 01 60
40	001 99 01 22 70	001 99 01 12 70	001 99 01 01 70	001 99 04 01 70

— OPTIONALS - OPCIONALES —

K

40	305 01 29 50 20	351 01 08 02 00	305 08 27 46 15
50	305 01 45 00 20	351 01 08 04 00	305 08 48 69 20

TYPE	TIPO	TOOL Ø HERRAMIENTA	LENGTH	LONGITUD
	30, 40	2 - 28		M

ISO DIN 2080 Taper
Cono ISO. DIN 2080

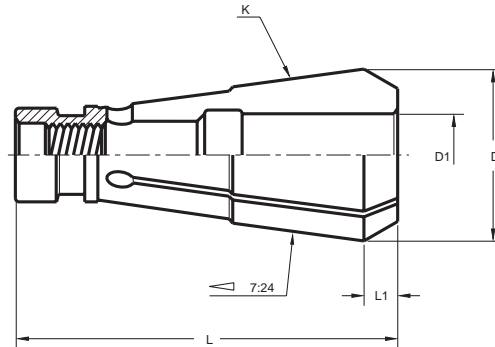

K	D	LENGTH - LONGITUD		L ₁	D ₁	COD.
		L				
30	31,75	76	7		2	002 54 01 02 00
					3	002 54 01 03 00
					4	002 54 01 04 00
					5	002 54 01 05 00
					↓	↓
					15	002 54 01 15 00
					16	002 54 01 16 00
					17	002 54 01 17 00
					18	002 54 01 18 00
					19	002 54 01 19 00
40	44,45	102	9		20	002 54 01 20 00
					4	002 54 02 04 00
					5	002 54 02 05 00
					6	002 54 02 06 00
					7	002 54 02 07 00
					↓	↓
					25	002 54 02 25 00
					26	002 54 02 26 00
					27	002 54 02 27 00
	28	002 54 02 28 00				

Material: Spring steel
Tempered
Rc 57 ÷ 60

Material: Acero de muelles.
Ejecución: Templado y rectificado.
Dureza Rc 57 ÷ 60.

TYPE TIPO	TYPE TIPO	LENGTH LONGITUD
30, 40, 50	K1- K5	M

With double effect pull stud. For Morse taper tools with thread DIN 228-A
Con tirante de doble efecto. Para herramientas con rosca de tiro DIN 228-A

DIN 6364 (*)

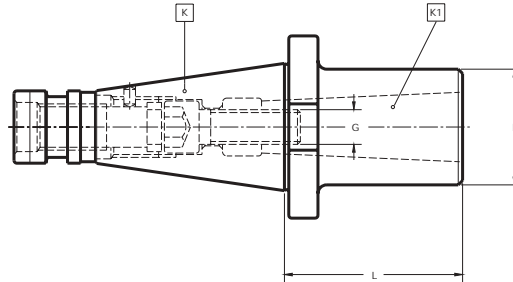

Maximum circular deviation between K and K₁ ≤ 0,008
Desviación circular máxima entre K y K₁ ≤ 0,008

K	K ₁	LENGTH - LONGITUD L	D	G	COD.
30	1	50	25	M-6	003 05 02 01 20
30	2	50	32	M-10	003 05 02 01 30
30	3	72	36	M-12	003 05 02 01 40
40	1	52	25	M-6	003 05 02 02 20
40	2	52	32	M-10	003 05 02 02 30
40	3	62	40	M-12	003 05 02 02 40
*40	4	97	48	M-16	003 05 02 02 50
40	4	con arrastre según DIN 2201 ver pág. 6/14 COD. 003 05 04 02 50 with diving slot DIN 2201 see page 6/14 COD. 003 05 04 02 50			
50	2	60	32	M-10	003 05 02 04 30
50	3	65	40	M-12	003 05 02 04 40
*50	4	65	48	M-16	
50	4	con arrastre según DIN 2201 ver pág. 6/14 COD. 003 05 04 04 50 with diving slot DIN 2201 see page 6/14 COD. 003 05 04 04 50			
*50	5	100	63	M-20	
50	5	con arrastre según DIN 2201 ver pág. 6/14 COD. 003 05 04 04 60 with diving slot DIN 2201 see page 6/14 COD. 003 05 04 04 60			

* These positions are not according to DIN 6364 (No driving slot DIN 2201)

* Estas posiciones no cumplen la norma DIN 6364 por carecer del arrastre según DIN 2201

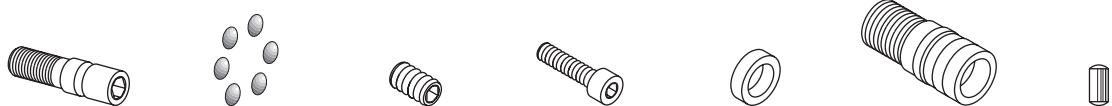

COD.							
003 05 02 01 20	003 99 08 01 20	304 01 00 03 00	301 01 07 04 05				
003 05 02 01 30	003 99 08 01 30	304 01 00 03 00	301 01 07 04 05				
003 05 02 01 40	003 99 08 01 40	304 01 00 03 00	301 01 07 04 05				
003 05 02 02 20			301 01 01 06 35	351 03 05 02 04	351 03 05 02 02	301 04 04 00 50	
003 05 02 02 30			301 01 01 10 35	351 03 05 02 05	351 03 05 02 02	301 04 04 00 50	
003 05 02 02 40			301 01 01 12 35	351 03 05 02 06	351 03 05 02 02	301 04 04 00 50	
003 05 02 02 50			003 99 07 09 15	351 03 05 02 07	351 03 05 02 02	301 04 04 00 50	
003 05 02 04 30			301 01 01 10 70	351 03 05 02 09	351 03 05 02 03	301 04 04 01 00	
003 05 02 04 40			301 01 01 12 60	351 03 05 02 10	351 03 05 02 03	301 04 04 01 00	
003 05 02 04 50			301 01 01 16 45	351 03 05 02 11	351 03 05 02 03	301 04 04 01 00	
003 05 02 04 60			301 01 01 20 55	351 03 05 02 12	351 03 05 02 03	301 04 04 01 00	

TYPE TIPO	TYPE TIPO	LENGTH LONGITUD
30, 40, 50	K1 - K3	M

For Morse taper tools with thread DIN 228-A
Para herramientas con rosca de tiro DIN 228-A

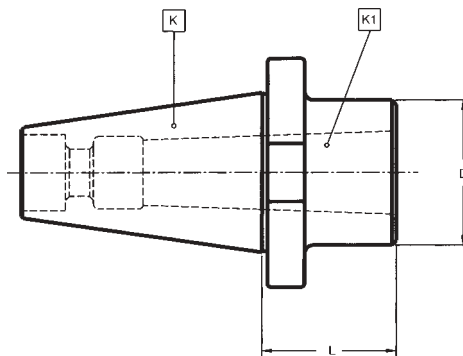

K	K ₁	LENGTH - LONGITUD		D	COD.	OPCIONAL (*)
		L				
30	1	35		25	003 05 03 01 20	003 99 03 01 20
30	2	46		32	003 05 03 01 30	003 99 03 01 30
30	3	72		36	003 05 03 01 40	003 99 03 01 40
40	1	22		25	003 05 03 02 20	003 99 03 02 20
40	2	22		32	003 05 03 02 30	003 99 03 02 30
50	2	24		32	003 05 03 04 30	003 99 03 04 30
50	3	24		40	003 05 03 04 40	003 99 03 04 40

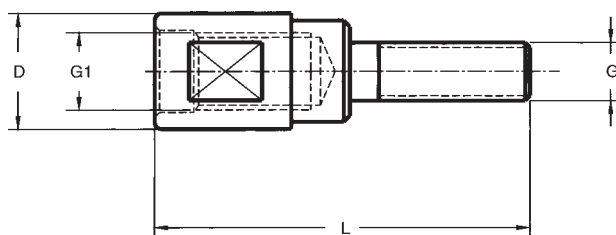

COD.	D ₁	G ₁	G	L	COD. (*)
003 05 03 01 20	17	M-12	M-6	65	003 99 03 01 20
003 05 03 01 30	17	M-12	M-10	73	003 99 03 01 30
003 05 03 01 40	17	M-12	M-12	85	003 99 03 01 40
003 05 03 02 20	25	M-16	M-6	78	003 99 03 02 20
003 05 03 02 30	25	M-16	M-10	75	003 99 03 02 30
003 05 03 02 50	25	M-16	M-16	95	003 99 03 02 50
003 05 03 04 30	39	M-24	M-10	111	003 99 03 04 30
003 05 03 04 40	39	M-24	M-12	98	003 99 03 04 40
003 05 03 04 50	39	M-24	M-16	102	003 99 03 04 50
003 05 03 04 60	39	M-24	M-20	112	003 99 03 04 60

(*) Pull studs supplied only under request.

(*) Estos tirantes son suministrados bajo demanda expresa.

TYPE TIPO	TYPE TIPO	LENGTH LONGITUD
40, 50	K4 - K5	M

With double effect pull stud. For Morse taper tools with thread DIN 228-A
Con tirante de doble efecto. Para herramientas con rosca de tiro DIN 228-A

DIN 6364 (DIN 2201)

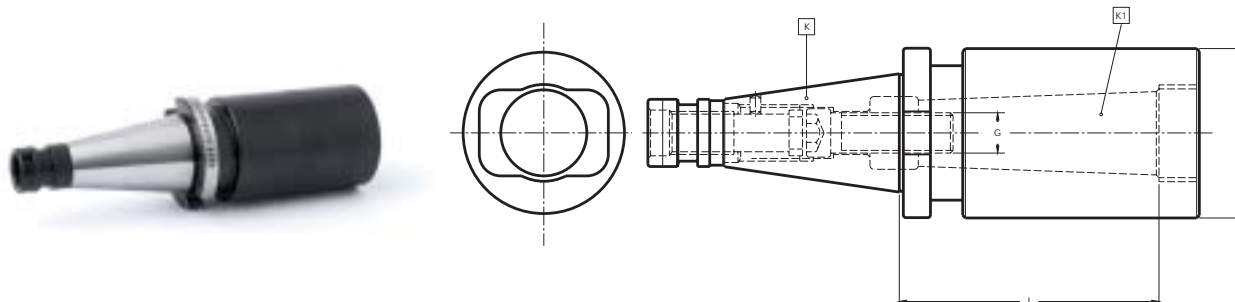

Maximum circular deviation between K and K₁ ≤ 0,008
Desviación circular máxima entre K y K₁ ≤ 0,008

K	K ₁	LENGTH - LONGITUD L	D	G	COD.
40	4	97	63	M-16	003 05 04 02 50
40	4	sin arrastre según DIN 2201 ver pág. 6/12 COD. 003 05 02 02 50 without driving slot DIN 2201 see page 6/12 COD. 003 05 02 02 50			
50	4	75	63	M-16	003 05 04 03 50
50	4	sin arrastre según DIN 2201 ver pág. 6/12 COD. 003 05 02 04 50 without driving slot DIN 2201 see page 6/12 COD. 003 05 02 02 50			
50	4	65	63	M-16	003 05 04 04 50
50	5	sin arrastre según DIN 2201 ver pág. 6/12 COD. 003 05 02 04 60 without driving slot DIN 2201 see page 6/12 COD. 003 05 02 02 50			
50	5				

COD.
003 05 04 02 50

003 99 07 09 15

351 03 05 02 07

351 03 05 02 02

301 04 04 00 50

003 05 04 04 50
003 05 04 04 60

301 01 01 16 45
301 01 01 20 55

351 03 05 02 11
351 03 05 02 12

351 03 05 02 03
351 03 05 02 03

301 04 04 01 00
301 04 04 01 00

TYPE TIPO	TOOL Ø HERRAMIENTA	LENGTH LONGITUD
30, 40, 45, 50	K4 - K5	S M

For tapered Morse taper tools DIN 228-B or Morse taper tools with thread DIN 228-A
Para herramientas con lengüeta DIN 228-B o rosca de tiro DIN 228-A

Alternative solutions

003 05 54 + 003 54 12 pgs. 6/20 y 9/6

Soluciones alternativas

DIN 6383

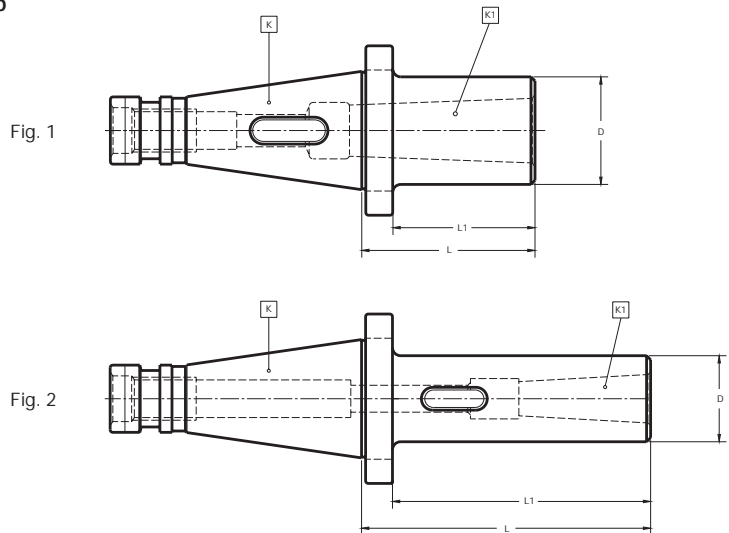

Maximum circular deviation between K and K₁ ≤ 0,008
Desviación circular máxima entre K y K₁ ≤ 0,008

FIG.	K	K ₁	LENGTH - LONGITUD		L ₁	D	COD.	 (1)
			L	L				
1	30	1	50		40	25	003 05 12 01 20	301 01 01 06 35
2	30	1		92	82	25	003 05 12 01 21	301 01 01 06 60
1	*30	2	50		40	32	003 05 11 01 30	
2	*30	2		102	92	32	003 05 11 01 31	
1	*30	3	72		62	40	003 05 11 01 40	
1	40	1	50		38	25	003 05 12 02 20	301 01 01 06 40
2	40	1		92	80	25	003 05 12 02 21	301 01 01 06 80
1	40	2	50		38	32	003 05 12 02 30	003 99 07 06 15
2	40	2		109	97	32	003 05 12 02 31	003 99 07 06 20
1	*40	3	65		53	40	003 05 11 02 40	
1	*40	4	95		83	48	003 05 11 02 50	
2	*40	4		152	140	48	003 05 11 02 51	
1	45	1	50		35	25	003 05 12 03 20	301 01 01 06 45
1	45	2	50		35	32	003 05 12 03 30	301 01 01 10 55
1	45	3	65		50	40	003 05 12 03 40	003 99 06 07 17
1	50	1	50		35	25	003 05 12 04 20	301 01 01 06 10
1	50	2	60		45	32	003 05 12 04 30	301 01 01 10 12
1	50	3	65		50	40	003 05 12 04 40	301 01 01 12 55
2	50	3		133	118	40	003 05 12 04 41	301 01 01 12 12
1	50	4	70		55	48	003 05 12 04 50	003 99 07 09 18
2	50	4		163	148	48	003 05 12 04 51	003 99 07 09 22
1	*50	5	105		90	63	003 05 11 04 60	
2	*50	5		193	178	63	003 05 11 04 61	

(1) Pull stud for tools with tightening thread.

(*) These adapters cannot be used for tools with Morse taper shank with tightening thread DIN 228-A.

(1) Tirante necesario para usar herramienta con rosca de tiro.

(*) Estos reductores no permiten el uso de herramientas con mango con rosca de tiro DIN 228-A.

TYPE TIPO	TYPE TIPO	LENGTH LONGITUD
30, 40, 50	K3 - K5	S M L

For tapered Morse taper tools DIN 228-B
Para herramientas con lengüeta DIN 228-B

Alternative solutions

003 05 54 + 003 54 12 pgs. 6/20 y 9/6

Soluciones alternativas

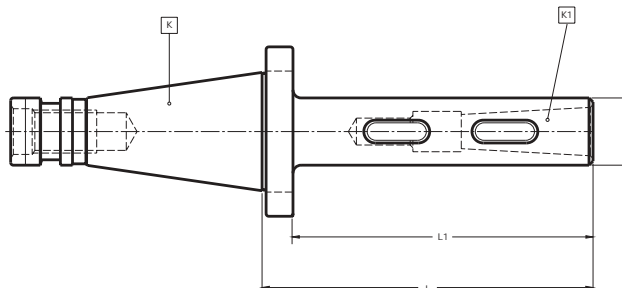

Maximum circular deviation between K and K₁

0,015 → L₁ = 200, 250 and 315

0,020 → L₁ = 400

0,025 → L₁ = 500

Desviación circular máxima entre K y K₁

0,015 → L₁ = 200, 250 y 315

0,020 → L₁ = 400

0,025 → L₁ = 500

K	K ₁	L ₁	LENGTH - LONGITUD			D	COD.
			L				
30	3	250	260			32	003 05 13 01 41
30	3	315		325		32	003 05 13 01 42
40	3	250	262			32	003 05 13 02 41
40	3	400		412		32	003 05 13 02 43
40	3	500			512	32	003 05 13 02 44
40	5	400		412		56	003 05 13 02 63
40	5	500			512	56	003 05 13 02 64
50	4	315	330			40	003 05 13 04 52
50	5	315	330			56	003 05 13 04 62
50	5	400		415		56	003 05 13 04 63

TYPE TIPO	Ø	LENGTH LONGITUD
40, 50	28 - 48	M L

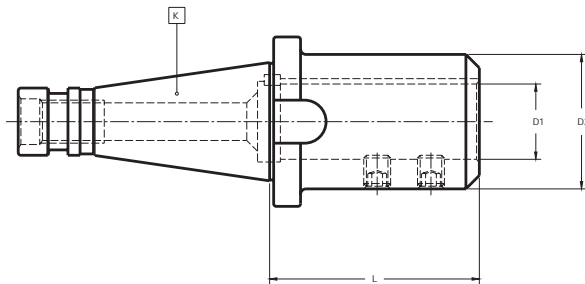

Maximum circular deviation between K and D₁ ≤ 0,008
 Desviación circular máxima entre K y D₁ ≤ 0,008

K	D ₁ H6	LENGTH - LONGITUD		D ₂	COD.	
		L				
40	28	75		50	003 05 21 02 61	301 01 03 10 12
40	36	120		63	003 05 21 02 83	301 01 03 12 14
50	20	75		45	003 05 21 04 41	301 01 03 08 12
50	28	100		55	003 05 21 04 62	301 01 03 12 14
50	28		150	55	003 05 21 04 64	301 01 03 12 14
50	36	100		63	003 05 21 04 82	301 01 03 12 14
50	36		150	63	003 05 21 04 84	301 01 03 12 14
50	48	150		78	003 05 21 04 94	301 01 03 12 16

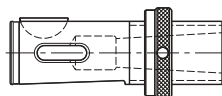

003 51 11 ...

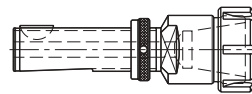

004 51 06 ...

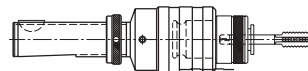

019 51 02 ...

See pages 12/02 - 12/06
 Ver págs. 12/02 - 12/06

TYPE TIPO	TYPE TIPO	LENGTH LONGITUD
40, 50	30 - 40	M

For tools with DIN 2080, DIN 69871 or MAS-BT taper
Para herramientas con cono DIN 2080, DIN 69871 y MAS-BT

DIN 6363

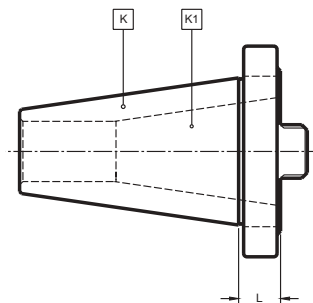

Maximum circular deviation between K and $K_1 \leq 0,008$
Desviación circular máxima entre K y $K_1 \leq 0,008$

K	K_1	LENGTH - LONGITUD L	COD.
40	30	12	003 05 31 02 01
50	40	16	003 05 31 04 02

TYPE TIPO	TOOL Ø HERRAMIENTA	LENGTH LONGITUD
40, 50, 60	30 - 40	M

With double effect pull stud. For tools with taper DIN 2080
Con tirante de doble efecto. Para herramientas con cono DIN 2080

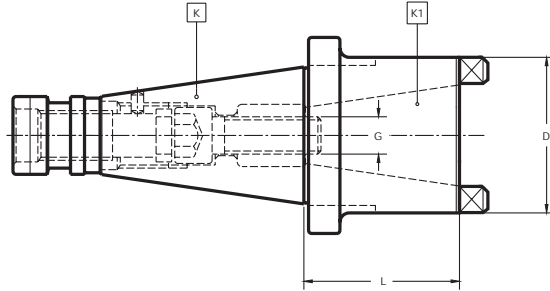

Maximum circular deviation between K and K₁ ≤ 0,008
Desviación circular máxima entre K y K₁ ≤ 0,008

K	K ₁	LENGTH - LONGITUD L	D	G	COD.
40	30	50	52	M-12	003 05 32 02 01
45	40	65	70	M-16	003 05 32 03 02
50	30	30	62	M-12	003 05 32 04 01
50	40	58	70	M-16	003 05 32 04 02
60	40	40	88	M-16	003 05 32 06 02

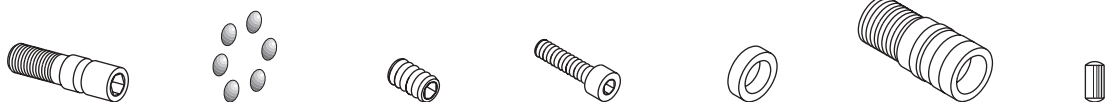

COD.							
003 05 32 02 01				301 01 01 12 35	351 03 05 02 06	351 03 05 02 02	301 04 04 00 50
003 05 32 03 02	003 99 08 03 50	304 01 00 04 00	301 01 03 05 12				
003 05 32 04 01				301 01 01 12 35	351 03 05 02 10	351 03 05 02 03	301 04 04 01 00
003 05 32 04 02				301 01 01 16 45	351 03 05 02 11	351 03 05 02 03	301 04 04 01 00

TYPE TIPO	OUTSIDE Ø EXTERIOR	LENGTH LONGITUD
30, 40, 45, 50, 60	46 - 90	M

Interchangeable with C.O. system
Intercambiable con el sistema C.O.

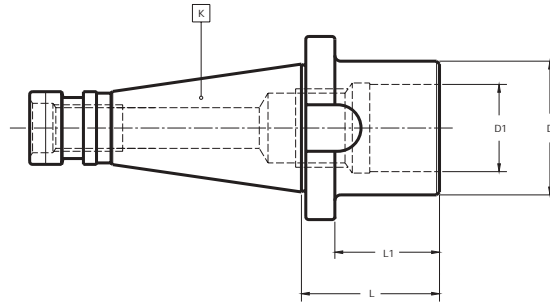

Maximum circular deviation between K and D₁ ≤ 0,005
Desviación circular máxima entre K y D₁ ≤ 0,005

K	K ₁ H5	D	LENGTH - LONGITUD		L ₁	COD.
			L			
30	30	46	60		50	003 05 54 01 06
40	30	46	40		28	003 05 54 02 06
40	46	63	85		75	003 05 54 02 07
45	30	46	40		25	003 05 54 03 06
45	46	63	75		60	003 05 54 03 07
50	30	46	50		35	003 05 54 04 06
50	46	63	50		35	003 05 54 04 07
50	46	90	50		35	003 05 54 04 08
60	46	90	54		35	003 05 54 06 08

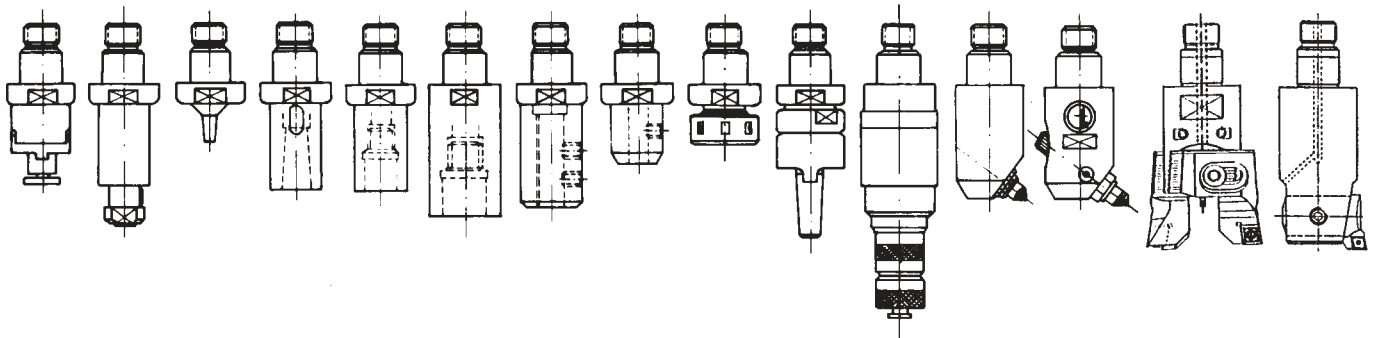

See pages 9/2
Ver págs. 9/2

TYPE TIPO	Ø MAX	LENGTH LONGITUD
30, 40, 50	20 - 40	M

For tools with cylindrical straight shank DIN 1835-A or threaded cylindrical shank DIN 1835-D
 Para herramientas con mango cilíndrico liso DIN 1835-A o cilíndrico roscado DIN 1835-D

Alternative solutions 004 05 15 pg. 6/23
 Soluciones alternativas 004 05 06 pg. 6/24 y 6/25
 003 05 54 + 004 54 06 pgs. 6/20 y 9/10

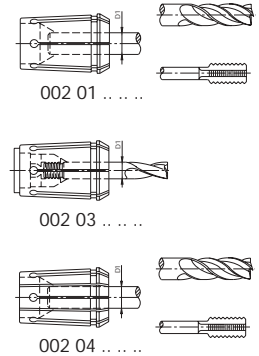
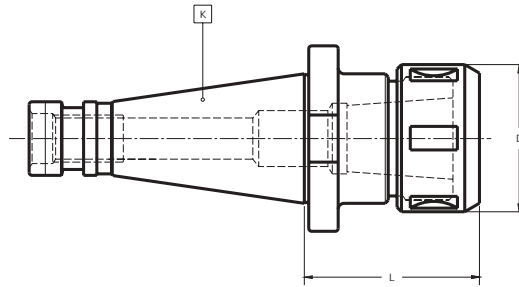

Maximum circular deviation between outer taper and collet housing $\leq 0,003$
 Desviación circular máxima entre el cono exterior e interior $\leq 0,003$

COLLETS see pages 14/3 - 14/4
 PINZAS ver págs. 14/3 - 14/4

K	D ₁ max	LENGTH - LONGITUD L	D	COD.
30	20	58	50	004 05 01 01 04
30	25	70	60	004 05 01 01 05
40	20	60	50	004 05 01 02 04
40	25	63	60	004 05 01 02 05
40	32	86	72	004 05 01 02 06
50	25	67	60	004 05 01 04 05
50	32	68	72	004 05 01 04 06
50	40	76	85	004 05 01 04 07

For boxes and composition of different sets see pages 14/12.
 Estuches y composición de diferentes juegos, ver págs. 14/12.

Accessories, see pages 281-297 - Accesorios ver págs. 16/3 - 16/11

BALANCED NUT
 TUERCA EQUILIBRADA

BEARING NUT
 TUERCA GIRATORIA

WRENCH
 LLAVE
 (OPTIONAL - OPCIONAL)

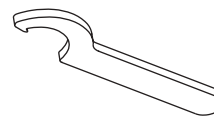
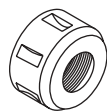

D₁ máx.



20	004 99 01 01 04	004 99 01 02 04	004 99 04 09 09
25	004 99 01 01 05	004 99 01 02 05	004 99 04 09 11
32	004 99 01 01 06	004 99 01 02 06	004 99 04 09 12
40	-	004 99 01 02 07	004 99 04 09 13

TYPE TIPO	Ø MAX	LENGTH LONGITUD
40, 50	20 - 32	M

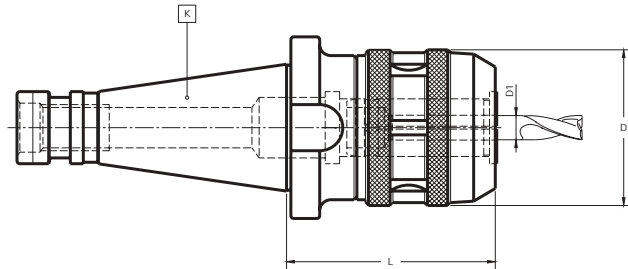
For tools with plain cylindrical straight shank
Para herramientas con mango cilíndrico



Maximum circular deviation between outer taper and collet housing $\leq 0,003$
Desviación circular máxima entre el cono exterior y el alojamiento de la pinza $\leq 0,003$

K	D ₁ max	LENGTH - LONGITUD		D	COD.		
		L					
40	20	60		54	004 05 05 02 04	004 99 04 02 06	OPCIONAL 004 99 04 09 10
40	32	82		72	004 05 05 02 06	004 99 04 02 06	004 99 04 09 12
50	32	75		72	004 05 05 04 06	004 99 04 02 06	004 99 04 09 12

In order to achieve best results we recommend to use cylindrical tools with h6 tolerance.
When tool shank diameter is 'D₁ max.', there is no need of any collet.

For boxes and composition of different sets see pages 14/12

Para un máximo rendimiento del portapinzas se recomienda utilizar herramientas de mango cilíndrico con tolerancia h6
La herramienta cuyo diámetro corresponda a 'D₁ máx.', se sujeta sin necesidad de pinza.

Estuches y composición de diferentes juegos, ver págs. 14/12

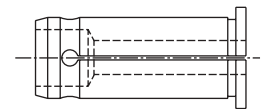

002 05
See page 14/9 - Ver pág. 14/9

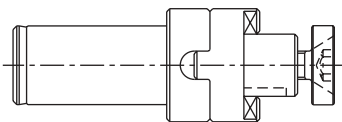

001 50 02 06 ..
See page 10/3 - Ver pág. 10/3

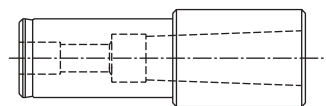

003 50 12 06 ..
See page 10/3 - Ver pág. 10/3

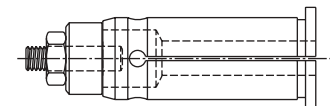

002 07
See page 14/9 - Ver pág. 14/9

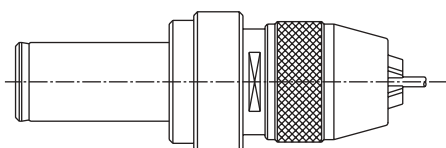

012 50 09
See page 10/5 - Ver pág. 10/5

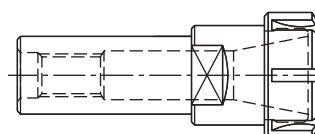

004 50 06
See page 10/4 - Ver pág. 10/4

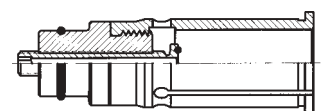

002 09
See page 14/9 - Ver pág. 14/9

TYPE TIPO	Ø MAX	LENGTH LONGITUD
40, 50	20 - 32	M

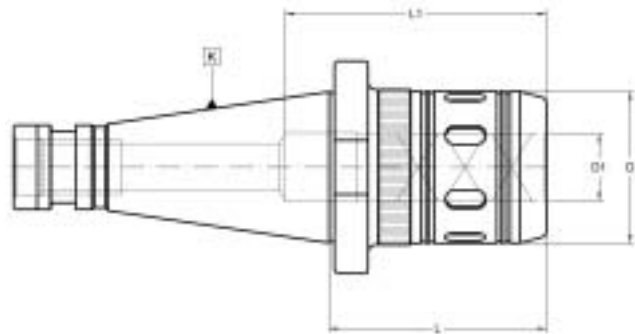

Maximum circular deviation between outer taper and collet housing $\leq 0,003$ mm.
Desviación circular máxima entre el cono exterior y el alojamiento de la pinza $\leq 0,003$ mm.

K	D ₁ máx.	LENGTH - LONGITUD		L ₁	D	COD.
		L	L			
40	20	65	65	60	46	004 05 15 02 04
40	32	80	80	75	62	004 05 15 02 06
50	20	70	70	60	46	004 05 15 04 04
50	32	75	75	80	62	004 05 15 04 06

In order to achieve best results we recommend to use cylindrical tools with h6 tolerance.
When tool shank diameter is 'D₁ max.', there is no need of any collet.

For boxes and composition of different sets see pages 4/12

Para un máximo rendimiento del portapinzas se recomienda utilizar herramientas de mango cilíndrico con tolerancia h6
La herramienta cuyo diámetro corresponda a 'D₁ máx.', se sujeta sin necesidad de pinza.

Estuches y composición de diferentes juegos, ver págs 4/12

ACCESORIES - ACCESORIOS

UNIVERSAL ARBOR PORTAFRESAS COMBINADO

001 50 02 06 ..

See page 10/3
Ver pág 10/3

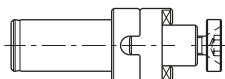

DRILL CHUCK PORTABROCAS INTEGRAL

012 50 09 16 13

See page 10/5
Ver pág 10/5

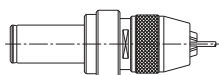

(ER) CILINDRICAL CHUCK PORTAPINZAS CILÍNDRICO (ER)

004 50 06 ...

See page 10/4
Ver pág 10/4

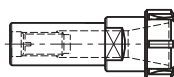

MORSE ADAPTOR REDUCTOR A CONO MORSE

003 50 12 06 ..

See page 10/3
Ver pág 10/3

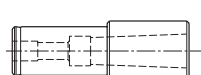

COLLETS PINZAS

002 05.. ...

See page 10/9
Ver pág 10/9



COLLETS PINZAS

002 09.. ...

See page 10/9
Ver pág 10/9

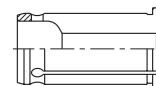

TYPE TIPO
30, 40, 50

TYPE TIPO
ER-16

LENGTH LONGITUD
M

Alternative solutions
Soluciones alternativas

003 05 54 + 004 54 06 págs. 6/20 y 9/10

For tools with cylindrical straight shank DIN 1835-A
Para herramientas con mango cilíndrico liso DIN 1835-A

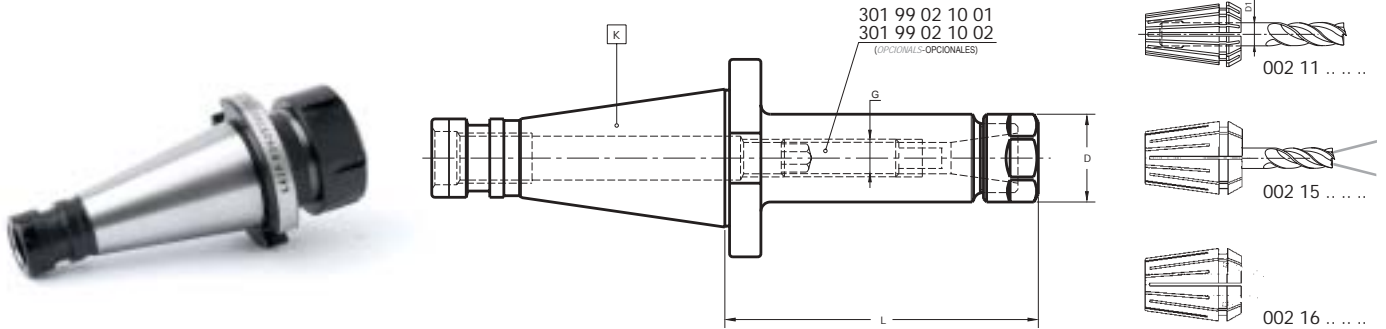

Maximum circular deviation between outer taper and collet housing $\leq 0,003$
Desviación circular máxima entre el cono exterior e interior $\leq 0,003$

Collets see pages 14/5 - 14/7
Pinzas ver págs. 14/5 - 14/7

K	SIZE / TAMAÑO	D ₁	LENGTH - LONGITUD L	D	G	COD.
30	(ER16)	0,5 - 10	42	28	M-10	004 05 06 01 03
40	(ER16)	0,5 - 10	60	28	M-10	004 05 06 02 03
40	(ER16)	0,5 - 10	100	28	M-10	004 05 06 02 13
50	(ER16)	0,5 - 10	100	28	M-10	004 05 06 04 13

Accessories, see pages 16/3 - 16/11
Accesorios ver págs. 16/3 - 16/11

BALANCED NUT
TUERCA EQUILIBRADA
(STANDARD - ESTÁNDAR)



SIZE - TAMAÑO
ER 16

004 99 01 08 03

BEARING NUT
TUERCA GIRATORIA
(OPTIONAL - OPCIONAL)



004 99 01 04 03

WRENCH
LLAVE
(OPTIONAL - OPCIONAL)

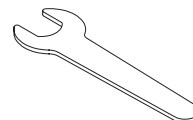

004 99 04 06 25

TYPE TIPO	TYPE TIPO	LENGTH LONGITUD
30, 40, 50	ER25 - ER50	M

Alternative solutions 004 05 15 pg. 6/23
Soluciones alternativas 004 05 01 pg. 6/21
003 05 54 + 004 54 06 pgs. 6/20 y 9/10

For tools with cylindrical straight shank DIN 1835-A
Para herramientas con mango cilíndrico liso DIN 1835-A

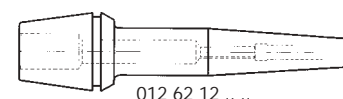
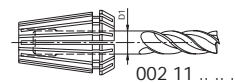
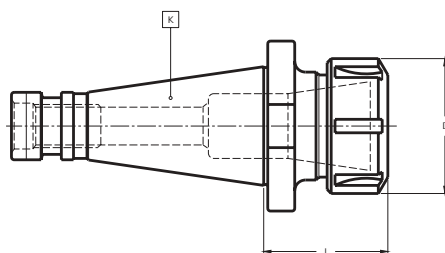

Maximum circular deviation between outer taper and collet housing $\leq 0,003$
Desviación circular máxima entre el cono exterior e interior $\leq 0,003$

Collets see pages 14/5 - 14/7
Pinzas ver págs. 14/5 - 14/7

K	SIZE / TAMAÑO	D ₁ máx.	LENGTH - LONGITUD L	D	COD.
30	(ER25)	16	45	42	004 05 06 01 05
30	(ER32)	20	56	50	004 05 06 01 06
40	(ER25)	16	45	42	004 05 06 02 05
40	(ER32)	20	52	50	004 05 06 02 06
40	(ER40)	26	53	63	004 05 06 02 07
40	(ER50)	34	80	78	004 05 06 02 08
50	(ER32)	20	70	50	004 05 06 04 06
50	(ER40)	26	70	63	004 05 06 04 07
50	(ER50)	34	70	78	004 05 06 04 08

For boxes and composition of different sets see pages 14/13.
Estuche y composición de diferentes juegos, ver págs. 14/13.

Accessories, see pages 16/3 - 16/11 - Accesorios ver págs. 16/3 - 16/11

BALANCED NUT
(STANDARD)

TUERCA EQUILIBRADA
(ESTÁNDAR)



BEARING NUT
(OPTIONAL)

TUERCA GIRATORIA
(OPCIONAL)



WRENCH
(OPTIONAL)

LLAVE
(OPCIONAL)

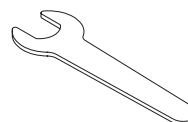

SIZE - TAMAÑO
ER 16

004 99 01 08 03

004 99 01 04 03

004 99 04 06 25

TYPE TIPO	INSIDE Ø INTERIOR	LENGTH LONGITUD
30, 40, 50	40 - 68,7	M

Without stopping the machine.
No requiere parada de máquina.

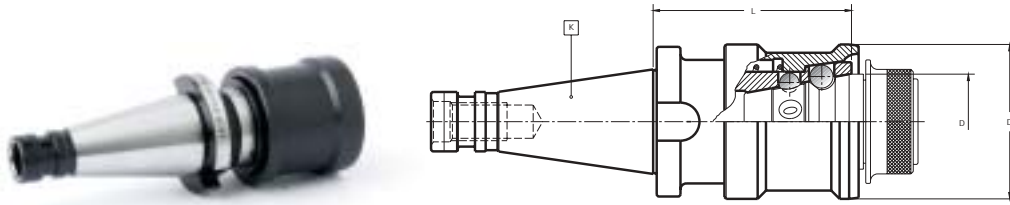

Maximum circular deviation between tapers $\leq 0,008$
Desviación circular máxima entre el cono exterior e interior $\leq 0,008$

K	D	LENGTH - LONGITUD L	D ₁	COD.
30	40	78	63	006 05 01 01 02
30	51,5	82	83	006 05 01 01 03
40	40	86	63	006 05 01 02 02
40	51,5	102	83	006 05 01 02 03
50	51,5	100	83	006 05 01 04 03
50	68,7	133	100	006 05 01 04 04

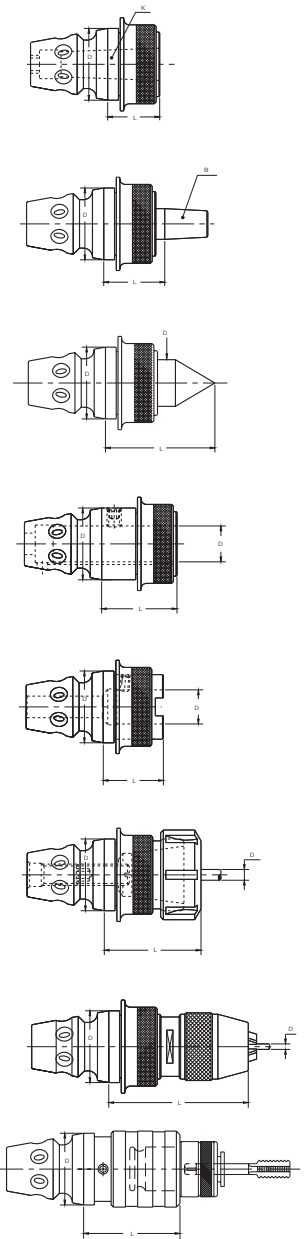

Without stopping the machine
Sin parar la máquina

Maximum rotation speed:
2,000 rpm
Velocidad de giro máxima:
2.000 rmp

Maximum concentricity achieved by taper coupling
Manteniendo la máxima concentricidad gracias a su acoplamiento cónico

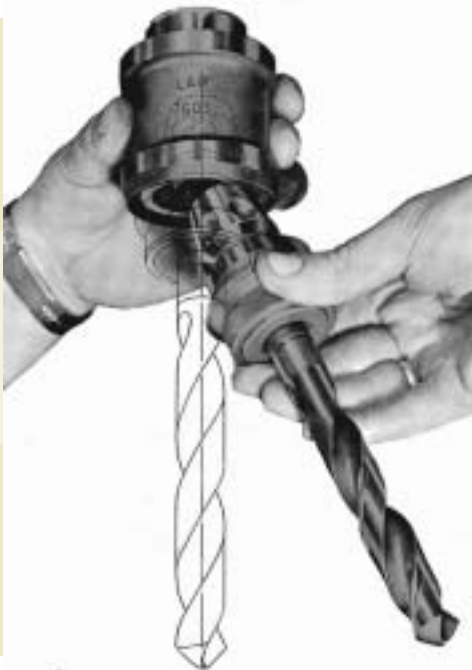

Just 10 mm clearance between workpiece and tool is enough
Siendo suficiente el espacio de solamente 10 mm. entre pieza y herramienta

Equally effective in vertical or horizontal plain
Puede utilizarse vertical u horizontalmente

Rotation in either direction
No influye el sentido de giro

System not useful for milling
Sistema no válido para fresado

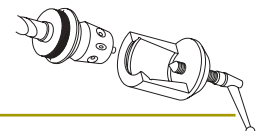

COD.						
006 05 01 01 02	304 01 00 08 73	304 01 00 10 31	305 01 40 00 20	305 09 06 01 02	351 06 00 01 21	351 06 00 01 22
006 05 01 01 03	304 01 00 11 11	304 01 00 12 70	305 01 51 00 20	305 09 06 01 03	351 06 00 01 31	351 06 00 01 32
006 05 01 02 02	304 01 00 08 73	304 01 00 10 31	305 01 40 00 20	305 09 06 01 02	351 06 00 01 21	351 06 00 01 22
006 05 01 02 03	304 01 00 11 11	304 01 00 12 70	305 01 51 00 20	305 09 06 01 03	351 06 00 01 31	351 06 00 01 32
006 05 01 04 03	304 01 00 11 11	304 01 00 12 70	305 01 51 00 20	305 09 06 01 03	351 06 00 01 31	351 06 00 01 32
006 05 01 04 04	304 01 00 12 70	304 01 00 14 28	305 01 51 00 30	305 09 06 01 04	351 06 00 01 41	351 06 00 01 42

For more details see page 7/15...21
Para ampliar detalles ver págs. 7/15...21

	D	27,1	40	51,5	68,7
MORSE TAPER ADAPTERS For tapered Morse taper tools DIN 228-B INTERIOR CONO MORSE Para herramientas con lengüeta <i>FLOATING ADAPTERS - FLOTANTE</i>	K ₁ Morse N°	1	1 2 3	1 2 3 4	1 2 3 4 5
	L	25	29 29 44	34 34 34 55	34 34 34 43 70
	COD. 006 99 01 □□□□	0102	0202 0203 0204	0302 0303 0304 0305	0402 0403 0404 0405 0406
	COD. 006 99 08 □□□□	-	- - 0204	- - 0304 -	- - - 0404 - -
DRILL CHUCK ADAPTERS For DIN 238 or JACOBS ESPIGA DIN 238 o JACOBS Para mandrinos porta-brocas	B	B. 12	B. 12 B. 16	B. 16	B. 16 B. 18
	L	28	32 34	39	39 39
	COD. 006 99 02 □□□□	0101	0201 0202	0302	0402 0403
60° CENTERING POINT ADAPTERS PUNTO DE CENTRADO DE 60°	L	49	61	66	66
	D ₁	16	26	26	26
	COD. 006 99 03 □□□□	0101	0201	0301	0401
AUTOMOTIVE ADAPTERS For tools with shank DIN 6327 INTERIOR CILINDRICO Para herramientas con mango DIN 6327 (regulación axial)	D ₁	-	20	28	36
	L	-	42	45	45
	COD. 006 99 04 □□□□	-	0204	0306	0408
TAPPING ADAPTERS For "BILZ" tap adapters CON ALOJAMIENTO PARA ADAPTADORES PORTAMACHOS TIPO BILZ	D ₁	-	13 19	19 31	31 48
	CAP.	-	M1-M10 M3-M12	M3-M12 M8-M20	M8-M20 M14-M33
	L	-	29 29	41 41	41 54
	COD. 006 99 05 □□□□	-	0201 0202	0302 0303	0403 0404
COLLET ADAPTERS For DIN 6499 (ER) collets PORTA-PINZAS DIN 6499 (ER) para pinza 002 11 ...	D ₁	0,5 - 10	0,5 - 16	0,5 - 16	0,5 - 16
	L	50	60	63	63
	COD. 006 99 06 06 □□	13	25	35	45
SHORT DRILL CHUCK ADAPTERS PORTABROCAS INTEGRAL (CORTO)	D ₁	-	0 - 8	1 - 13	1 - 13 3 - 16
	L	-	82	98	98 95
	COD. 006 99 07 □□□□	-	2008	3113	4113 4316
TAPPING ADAPTERS To use with "BILZ" adapters PORTA-MACHOS CON COMPENSACIÓN AXIAL DE AMBOS SENTIDOS Para utilizar adaptadores tipo "BILZ"	D ₁	19	19 31	19 31	31 48
	CAP.	M3-M12	M3-M12 M8-M20	M3-M12 M8-M20	M8-M20 M14-M33
	L	45	45 69	45 69	69 110
	COD. 006 99 19 52 □□	12	22 23	32 33	43 44
EJECTOR DEVICE For tools set up on 006 99 01 and 006 99 08 EXPULSOR DE HERRAMIENTA Para las herramientas montadas en adaptadores 006 99 01 y 006 99 08	COD. 006 99 09 01 □□	01	02	03	04

TYPE TIPO	TOOL Ø HERRAMIENTA	LENGTH LONGITUD
30, 40, 50	6 - 50	M

For end mills with shank DIN 1835-B - DIN 6535 HB
Para fresas con mango cilíndrico con encaste DIN 1835 Forma B - DIN 6535 Forma HB

Alternative solutions
Soluciones alternativas 003 05 54 + 012 54 04 págs. 6/20 y 9/18

DIN 6359 - 1

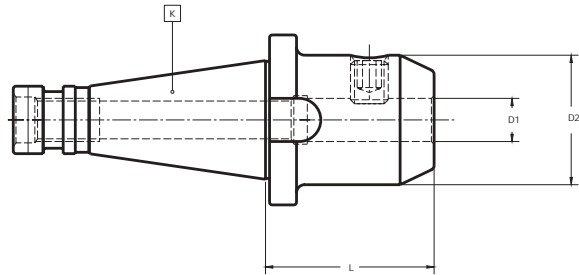

*Maximum circular deviation between K and $D_1 \leq 0,003$

*Desviación circular máxima entre K y $D_1 \leq 0,003$

K	D_1	*tol.	LENGTH - LONGITUD L	D_2	COD.	
30	6		40	25	012 05 01 11 06	301 01 05 06 10
30	8		40	28	012 05 01 11 08	301 01 05 08 10
30	10		40	35	012 05 01 11 10	301 01 05 10 12
30	12	$+0,005$ 0	40	42	012 05 01 11 12	301 01 05 12 16
30	14		50	44	012 05 01 11 14	301 01 05 12 16
30	16		50	48	012 05 01 11 16	301 01 05 14 16
30	18		63	50	012 05 01 11 18	301 01 05 14 16
30	20	$+0,007$ 0	63	52	012 05 01 11 20	301 01 05 16 16
40	6		50	25	012 05 01 12 06	301 01 05 06 10
40	8		50	28	012 05 01 12 08	301 01 05 08 10
40	10		50	35	012 05 01 12 10	301 01 05 10 12
40	12	$+0,005$ 0	50	42	012 05 01 12 12	301 01 05 12 16
40	14		50	44	012 05 01 12 14	301 01 05 12 16
40	16		63	48	012 05 01 12 16	301 01 05 14 16
40	18		63	50	012 05 01 12 18	301 01 05 14 16
40	20		63	52	012 05 01 12 20	301 01 05 16 16
40	25	$+0,007$ 0	80	65	012 05 01 12 25	301 01 05 18 20
40	32		80	72	012 05 01 12 32	301 01 05 20 20
50	6		63	25	012 05 01 14 06	301 01 05 06 10
50	8		63	28	012 05 01 14 08	301 01 05 08 10
50	10	$+0,005$ 0	63	35	012 05 01 14 10	301 01 05 10 12
50	12		63	42	012 05 01 14 12	301 01 05 12 16
50	14		63	44	012 05 01 14 14	301 01 05 12 16
50	16		63	48	012 05 01 14 16	301 01 05 14 16
50	18		63	50	012 05 01 14 18	301 01 05 14 16
50	20		63	52	012 05 01 14 20	301 01 05 16 16
50	25	$+0,007$ 0	80	65	012 05 01 14 25	301 01 05 18 20
50	32		80	72	012 05 01 14 32	301 01 05 20 20
50	40	$+0,009$ 0	90	90	012 05 01 14 40	301 01 05 20 25
50	50		100	98	012 05 01 14 50	301 01 05 24 25

* The hole diameter and circular deviation tolerances have been significantly tightened up compared with DIN 1835 in order to achieve the highest levels of machining precision.

$D_1 = > 25$ mm: two clamping holes.

* Para un mejor rendimiento, hemos restringido considerablemente las tolerancias que para el diámetro D_1 y la excentricidad establece la norma DIN 1835

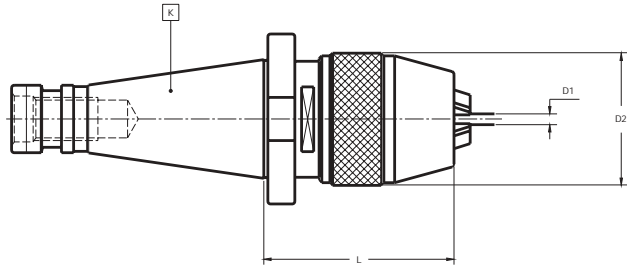

$D_1 = 25$ y mayores, con dos orificios para sujeción de herramienta.

TYPE TIPO	TOOL Ø HERRAMIENTA	LENGTH LONGITUD
30, 40, 50	0 - 16	M



*Maximum circular deviation between K and D₁ ≤ 0,03

*Desviación circular máxima entre K y D₁ ≤ 0,03

K	D ₁	LENGTH - LONGITUD L	D ₂	COD.			
30	0-8	75	36	012 05 09 11 08	351 02 60 00 08	351 02 61 00 08	020 99 03 00 08
40	1-13	81	48	012 05 09 12 13	351 02 60 01 13	351 02 61 01 13	020 99 03 01 13
40	3-16	97	54	012 05 09 12 16	351 02 60 03 16	351 02 61 03 16	020 99 03 03 16
50	3-16	72	54	012 05 09 14 16	351 02 60 03 16	351 02 61 03 16	020 99 03 03 16

TYPE TIPO	TOOL Ø HERRAMIENTA	LENGTH LONGITUD
40, 50	1 - 16	M

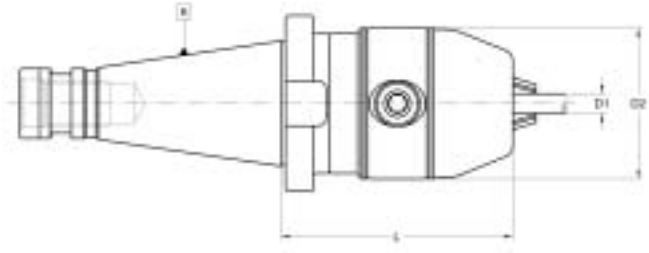

K	D ₁	D ₂	LENGTH - LONGITUD		COD.
			L		
40	1 - 13	53	82		012 06 19 12 13
40	3 - 16	53	85		012 06 19 12 16
50	1 - 13	57	85		012 06 19 14 13
50	3 - 16	57	88		012 06 19 14 16

TYPE TIPO	TOOL Ø HERRAMIENTA	LENGTH LONGITUD
30, 40, 50	M3 - M28	M

Self feed and compression system. Releasing drive system. For LAIP 0219 collet
Doble compensación axial y escape

Alternative solutions Soluciones alternativas 003 05 54 + 019 54 51 ... 2 págs. 6/20 y 9/19

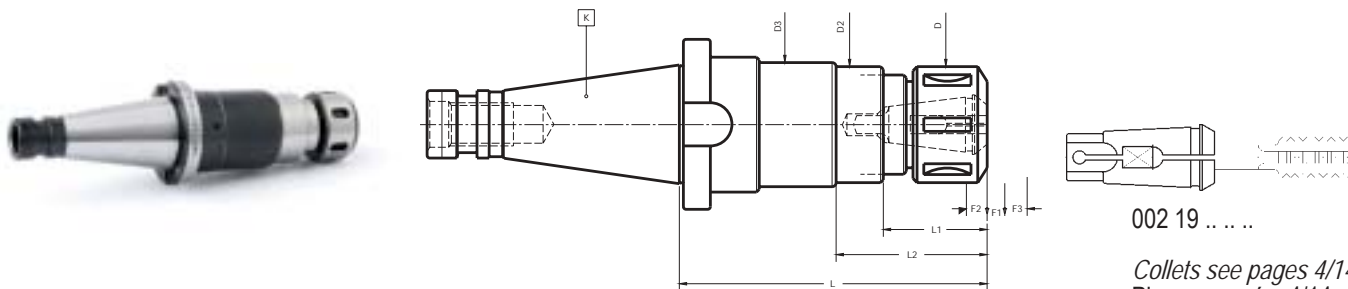

Collets see pages 4/14
Pinzas ver pág. 4/14

K	CAP.	LENGTH - LONGITUD L	D	L ₁	D ₂	L ₂	D ₃	F ₁	F ₂	F ₃	COD.
30	M3-M16	126	43	39	44	58	49	5	10	10	019 05 51 01 02 22
40	M3-M16	126	43	39	44	58	49	5	10	10	019 05 51 02 02 22
40	M8-M28	162	50	42	60	68	66	6	10	12	019 05 51 02 03 23
50	M3-M16	126	43	39	44	58	49	5	10	10	019 05 51 04 02 22
50	M8-M28	162	50	42	60	68	66	6	10	12	019 05 51 04 03 23

Axial compensation (compression and extensions) values are F₁ and F₂. F₃ is the release value (the tap receives only reversing rotation).
The release system allows to easily and accurately set up tapping depth, specially adapt for blind holes.

Las letras F₁ y F₂ corresponden a los recorridos de extensión y compresión respectivamente, siendo F₃ el recorrido en el que el macho no recibe movimiento de rotación en tanto no se invierta el sentido de giro (mecanismo de escape). Este mecanismo de escape o pérdida de arrastre, permite determinar exactamente la profundidad de roscado, facilitando enormemente el roscado de agujeros ciegos.

Accessories, see pages 16/3 - 16/11 - Accesorios ver págs. 16/3 - 16/11

BALANCED NUT
TUERCA EQUILBRADA
(STANDARD - ESTÁNDAR)

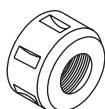

CAP.
M3-M16
M8-M28

-
004 99 01 01 04

BEARING NUT
TUERCA GIRATORIA
(OPTIONAL - OPCIONAL)



004 99 01 02 03
004 99 01 02 04

WRENCH
LLAVE
(OPTIONAL - OPCIONAL)

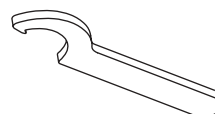

004 99 04 09 08
004 99 04 09 09

TYPE TIPO	CAP.	LENGTH LONGITUD
30, 40, 50	M3 - M30	M

Self feed and compression system. Releasing drive system. For BILZ system tap adapter
Doble compensación axial y escape

Alternative solutions Soluciones alternativas 003 05 54 + 019 54 51 ... 3 págs. 6/20 y 9/20

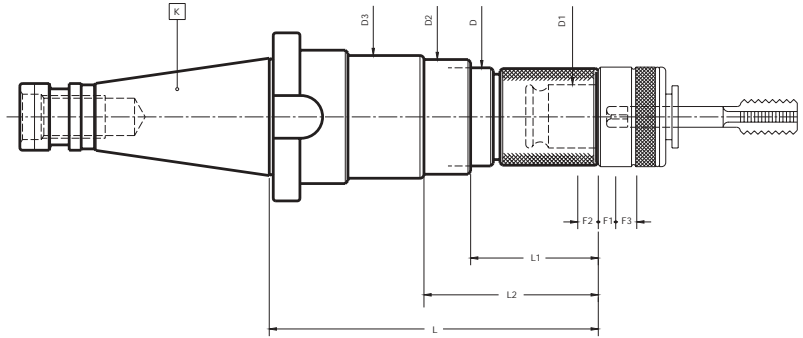

BILZ Adapter
Acoplamiento tipo BILZ

K	CAP.	D ₁	LENGTH - LONGITUD L	D	L ₁	D ₂	L ₂	D ₃	F ₁	F ₂	F ₃	COD.
30	M3-M12 (M16)*	19	131	37	44	44	63	49	5	10	10	019 05 51 01 02 32
40	M3-M12 (M16)*	19	131	37	44	44	63	49	5	10	10	019 05 51 02 02 32
40	M8-M20 (M30)*	31	183	51	63	60	89	66	6	10	12	019 05 51 02 03 33
50	M3-M12 (M16)*	19	131	37	44	44	63	49	5	10	10	019 05 51 04 02 32
50	M8-M20 (M30)*	31	183	51	63	60	89	66	6	10	12	019 05 51 04 03 33

Axial compensation (compression and extensions) values are F₁ and F₂. F₃ is the release value (the tap receives only reversing rotation). The release system allows to easily and accurately set up tapping depth, specially adapt for blind holes.

Las letras F₁ y F₂ corresponden a los recorridos de extensión y compresión respectivamente, siendo F₃ el recorrido en el que el macho no recibe movimiento de rotación en tanto no se invierta el sentido de giro (mecanismo de escape). Este mecanismo de escape o pérdida de arrastre, permite determinar exactamente la profundidad de roscado, facilitando enormemente el roscado de agujeros ciegos.

* With 002 22 ... and 002 24 ... adapters

* Con adaptadores 002 22 ... y 002 24 ...

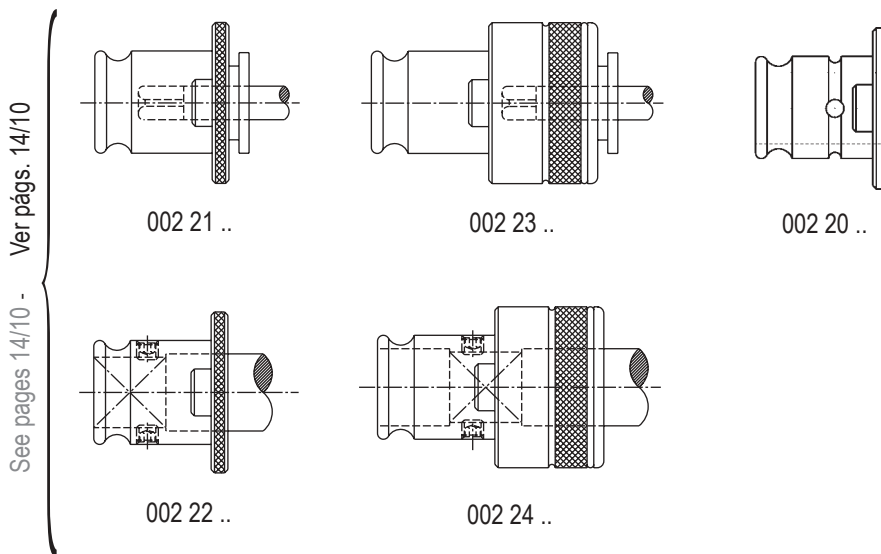

See pages 14/10 - Ver págs. 14/10

D ₁	OPTIONAL - OPCIONAL			
19	002 21 02	002 22 02	002 23 02	002 24 02
31	002 21 03	002 22 03	002 23 03	002 24 03

TYPE TIPO	CAP.	LENGTH LONGITUD
30, 40, 50	M3 - M48	M

Self feed and compression system. Releasing drive system. For BILZ system tap adapter
Doble compensación axial

Alternative solutions Soluciones alternativas 012 05 01 + 019 55 52 ... pág. 6/28 y 13/4

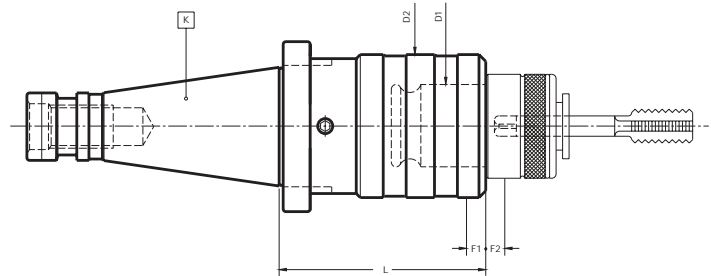

BILZ Adapter
Acoplamiento tipo BILZ

K	CAP.	D ₁	LENGTH - LONGITUD		D ₂	L ₁	D	COD.
			L					
30	M3-M12 (M16)*	19	60		36	7,5	7,5	019 05 52 01 02
40	M3-M12 (M16)*	19	50		36	7,5	7,5	019 05 52 02 02
40	M8-M20 (M30)*	31	78		53	12,5	12,5	019 05 52 02 03
40	M14-M33 (M48)*	48	130		78	20	20	019 05 52 02 04
50	M3-M12 (M16)*	19	75		36	7,5	7,5	019 05 52 04 02
50	M8-M20 (M30)*	31	80		53	12,5	12,5	019 05 52 04 03
50	M14-M33 (M48)*	48	130		78	20	20	019 05 52 04 04

F₁ Compression run
F₂ Extension run

F₁ Recorrido de compresión
F₂ Recorrido de extensión

* With 002 22 and 002 24 adapters

* Con adaptadores 002 22 y 002 24

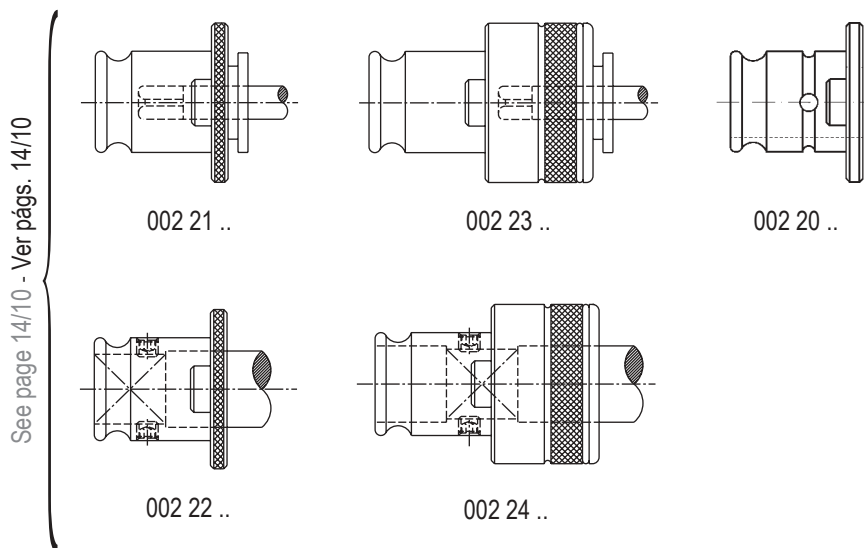

See page 14/10 - Ver págs. 14/10

D ₁	002 21 02	002 22 02	002 23 02	002 24 02
19	002 21 02	002 22 02	002 23 02	002 24 02
31	002 21 03	002 22 03	002 23 03	002 24 03
48	002 21 04	002 22 04	002 23 04	002 24 04

TYPE TIPO	Ø	LENGTH LONGITUD
40, 50	40 - 95	M L

Alternative solutions 003 05 54 + 020 54 02 págs. 6/20 y 9/21
 Soluciones alternativas

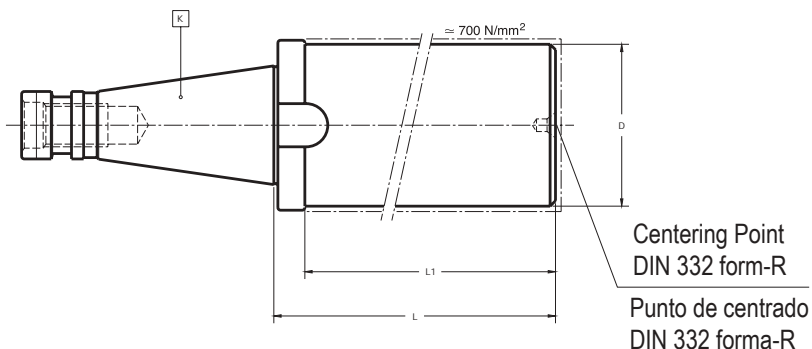

K	D	LENGTH - LONGITUD		L ₁	COD.
		L	L		
40	40	170		158	020 05 02 02 53
40	40		260	248	020 05 02 02 55
40	63	170		158	020 05 02 02 73
40	63		260	248	020 05 02 02 75
50	50	330		315	020 05 02 04 66
50	63	330		315	020 05 02 04 76
50	95	330		315	020 05 02 04 96

- The area of diameter D and length L_1 has 700 N/mm².
- Rest is hardened to 57 ÷ 60 Rc.

- La zona de diámetro D y longitud L_1 , se encuentra tratada con una resistencia aproximada de 700 N/mm².
- Las restantes zonas están cementadas, templadas y rectificadas con una dureza de 57 ÷ 60 Rc.