

NARZĘDZIA DO FREZOWANIA

TOOLS FOR MILLING

str. / page: rozdział / chapter:

- F2 **Głowice frezowe ECO 45**
ECO 45 milling cutters
- F3 **Frezy trzpieniowe ECO 45**
ECO 45 shank cutters
- F4 **Frezy SR.. do form i matryc**
SR.. ball nose milling cutters
- F6 **Frezy tarczowe NFTs..**
NFTs.. slitting cutters

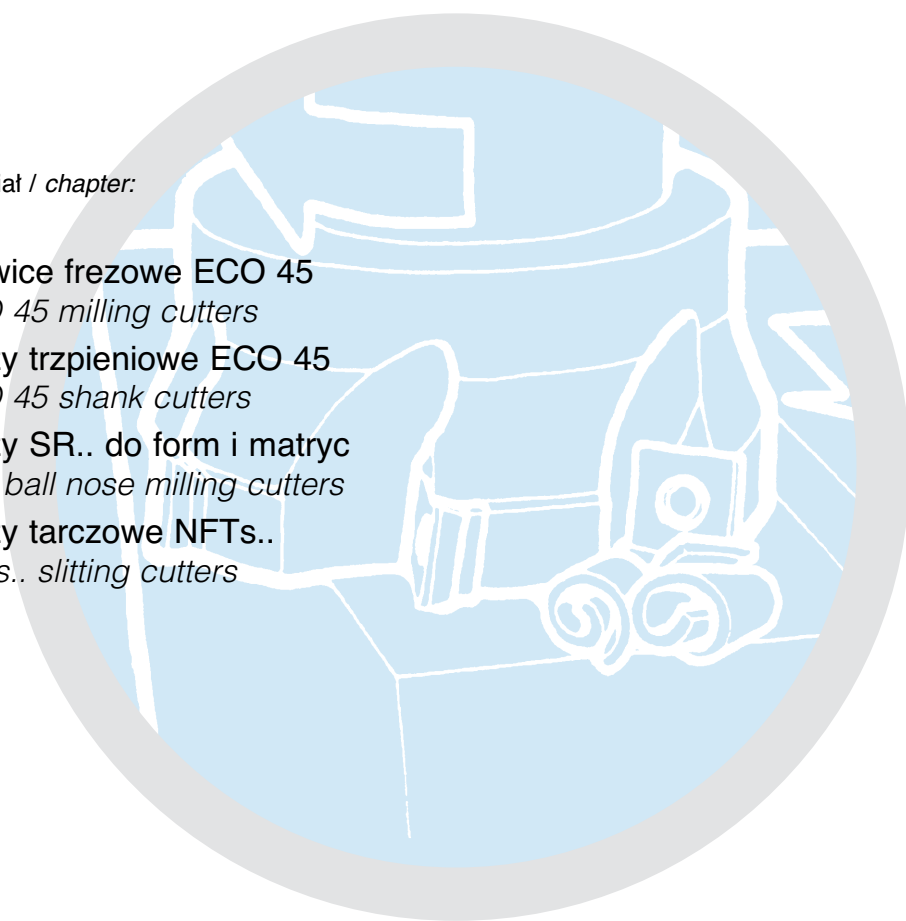

GQ..

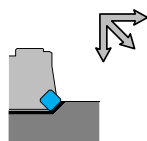

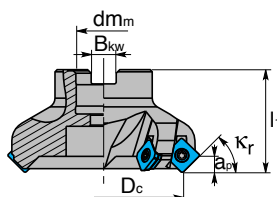

$$K_r = 45^\circ$$

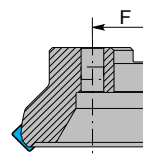

Ø 40 – Ø 125

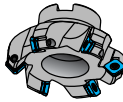

Ø 160

Oznaczenie Designation	Ilość ostrzy No. of teeth	D _c (mm)	a _p (mm)	B _{kw} (mm)	dm _m (mm)	F (mm)	l _i (mm)	kg
 GQ-12/040-03-AL-R	3	40	6	8,4	16	–	40	0,25
GQ-12/050-04-AL-R	4	50	6	10,4	22	–	40	0,30
GQ-12/063-05-AL-R	5	63	6	10,4	22	–	40	0,45
GQ-12/080-06-AL-R	6	80	6	12,4	27	–	50	0,80
GQ-12/100-07-AL-R	7	100	6	14,4	32	–	50	1,25
GQ-12/125-08-AL-R	8	125	6	16,4	40	–	63	2,65
GQ-12/160-10-AL-R	10	160	6	16,4	40	66,7	63	4,76
								
zwykła normal pitch								
 GQ-15/063-05-AS-R								
GQ-15/125-07-AL-R	7	125	8	16,4	40	–	63	2,25
GQ-15/160-08-AL-R	8	160	8	16,4	40	66,7	63	4,50

SDMT..AE/SDKT..AE



Części zamienne Spare parts

Średnica Ø (mm)
Diameter



Śruba
Screw



Klucz
Key



Smar
Grease



Zestaw
Kit



Śruba spec.
Spec. screw

D _c	40	12	DVF 2097	DMP 2099 (T20)	DDS 0463	DDR 2098	DVZ 1715
D _c	50	12	DVF 2097	DMP 2099 (T20)	DDS 0463	DDR 2098	28300
D _c	63 – 160	12	DVF 2097	DMP 2099 (T20)	DDS 0463	DDR 2098	–
D _c	50	15	DVF 2097	DMP 2099 (T20)	DDS 0463	DDR 2098	DVC 2103
D _c	63	15	DVF 2097	DMP 2099 (T20)	DDS 0463	DDR 2098	DVC 2102
D _c	80 – 160	15	DVF 2097	DMP 2099 (T20)	DDS 0463	DDR 2098	–

GQ..CM..

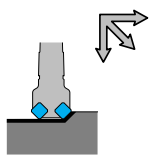

$$K_r = 45^\circ$$

CM

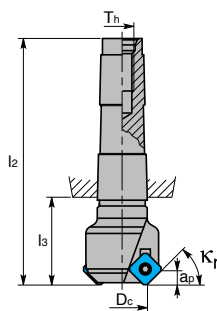

Oznaczenie Designation	Ilość ostrzy No. of teeth	D _c (mm)	a _p (mm)	T _h (mm)	l ₂ (mm)	l ₃ (mm)	Chwył Holder	kg
 GQ-12/032-03-CM3-5-R	3	32	6	M12	126	4	CM3	0,40

CM – Chwył Morse'a / Morse taper

SDMT..AE/SDKT..AE



Części zamienne Spare parts

Średnica Ø (mm)
Diameter



Śruba
Screw



Klucz
Key



Smar
Grease



Zestaw
Kit

D _c	32 – 40	12	DVF 2097	DMP 2099 (T20)	DDS 0463	DDR 2098
----------------	---------	----	----------	----------------	----------	----------

Frezy SR.. do form i matryc

SR.. ball nose milling cutters

SR..

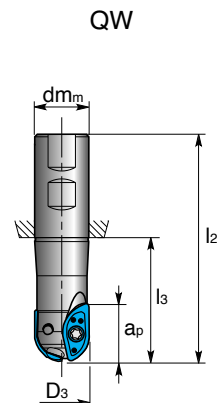
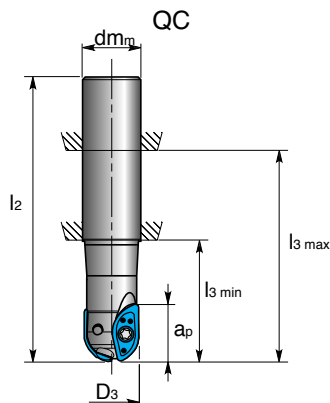
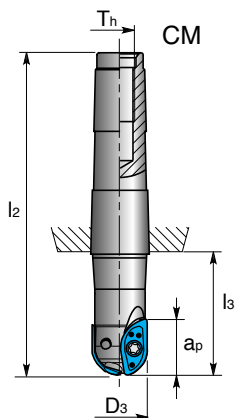
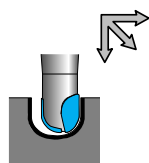

Oznaczenie Designation	Ilość ostrzy No. of teeth	D ₃ (mm)	a _p (mm)	dm _m (mm)	T _h (mm)	l ₂ (mm)	l ₃ (min/max) (mm)	Chwył Holder	
SR-10-02-CM2-050	2	10	8,9	-	M10	114	50	CM2	0,125
SR-10-02-QC16-160	2	10	8,9	16	-	160	40/128	QCØ16	0,215
SR-12-02-CM2-040	2	12	10,7	-	M10	104	40	CM2	0,111
SR-12-02-CM2-060	2	12	10,7	-	M10	124	60	CM2	0,135
SR-12-02-CM2-090	2	12	10,7	-	M10	154	90	CM2	-
SR-12-02-QW20-040	2	12	10,7	20	-	91	40	QW Ø20	0,155
SR-12-02-QW20-060	2	12	10,7	20	-	111	60	QW Ø20	0,185
SR-12-02-QC20-200	2	12	10,7	20	-	200	45/160	QC Ø20	0,431
SR-16-02-CM2-040	2	16	14,4	-	M10	104	40	CM2	0,115
SR-16-02-CM2-060	2	16	14,4	-	M10	124	60	CM2	0,145
SR-16-02-CM2-090	2	16	14,4	-	M10	154	90	CM2	-
SR-20-02-CM2-070	2	20	17,9	-	M10	134	70	CM2	0,179
SR-20-02-CM3-050	2	20	17,9	-	M12	131	50	CM3	0,273
SR-20-02-CM3-070	2	20	17,9	-	M12	151	70	CM3	0,325
SR-20-02-CM3-100	2	20	17,9	-	M12	181	100	CM3	0,387
SR-25-02-CM3-080	2	25	22,3	-	M12	161	80	CM3	0,386
SR-25-02-CM4-110	2	25	22,3	-	M16	212,5	110	CM4	0,760

CM - Chwył Morse'a / Morse taper
 QW - Chwył Weldona / Weldon shank
 QC - Chwył cylindryczny / Cylindrical shank

ZP..



Części zamienne Spare parts

Średnica D₃ (mm)
Diameter



Śruba
Screw



Śrubokręt
Screwdriver



Klucz
Key



Smar
Grease



Zestaw
Kit

Ø 10	DVF 2655	TX 206 PLUS	-	DDS 0463	
Ø 12	DVF 2564	TX 208 PLUS	-	DDS 0463	DDR 2565
Ø 16	DVF 2507	TX 208 PLUS	-	DDS 0463	DDR 2508
Ø 20	DVF 2394	TX 210 PLUS	-	DDS 0463	DDR 2395
Ø 25	DVF 2396	DMP 3125	DMP 2216	DDS 0463	DDR 2397

Przykład zamówienia / Ordering example: SR-10-02-CM2-050 - 1 szt. / pcs

Frezy SR.. do form i matryc

SR.. ball nose milling cutters

SR..

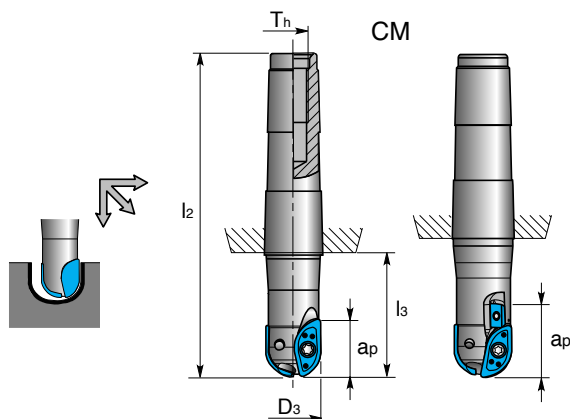

Oznaczenie Designation	Ilość ostrzy No. of teeth	Ilość płytek No. of inserts	D ₃ (mm)	a _p (mm)	dm _m (mm)	T _h (mm)	l ₂ (mm)	l ₃ (min/max) (mm)	Chwył Holder	kg
SR-32-02-CM4-100	2	2 ZP..	32	28,6	-	M16	202,5	100	CM4	0,825
SR-32-02-CM4-150	2	2 ZP..	32	28,6	-	M16	252,5	150	CM4	1,100
SR-32-03-CM4-100	2	2 ZP.. + 1 AP..	32	43,2	-	M16	202,5	100	CM4	0,820
SR-32-04-CM4-100	2	2 ZP.. + 2 AP..	32	57,7	-	M16	202,5	100	CM4	0,805
SR-40-04-CM5-150	2	2 ZP..+2 AP..	40	65	-	M20	279,5	150	CM5	2,260
SR-50-02-CM5-100	2	2 ZP..	50	44,7	-	M20	229,5	100	CM5	2,000
SR-50-06-CM5-150	2	2 ZP.. +4 AP..	50	103,3	-	M20	279,5	150	CM5	2,520

CM – Chwył Morse'a / Morse taper
 QW – Chwył Weldon / Weldon shank
 QC – Chwył cylindryczny / Cylindrical shank

Części zamienne Spare parts

Średnica D₃ (mm)
Diameter



Śruba
Screw



Klucz
Key



Pł. podporowa
Shim



Śruba
Screw



Śruba
Screw



Śrubokręt
Screwdriver

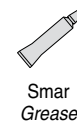

Smar
Grease



Zestaw
Kit

Ø 32	28349	DMP 2099	-	-	DVF 0089	TX 215 PLUS	DDS 0463	DDR 0649 DDR 0470
Ø 40	DVF 2193	DMP 3139	-	-	DVF 0089	TX 215 PLUS	DDS 0463	DDR 2194 DDR 0470
Ø 50	DVF 2447	DMP 2514	DAN 2391	DVF 0089	DVF 0089	TX 215 PLUS	DDS 0463	DDR 2448 DDR 0470

Przykład zamówienia / Ordering example: SR-32-02-CM3-100 – 1 szt. / pcs

NFTs..

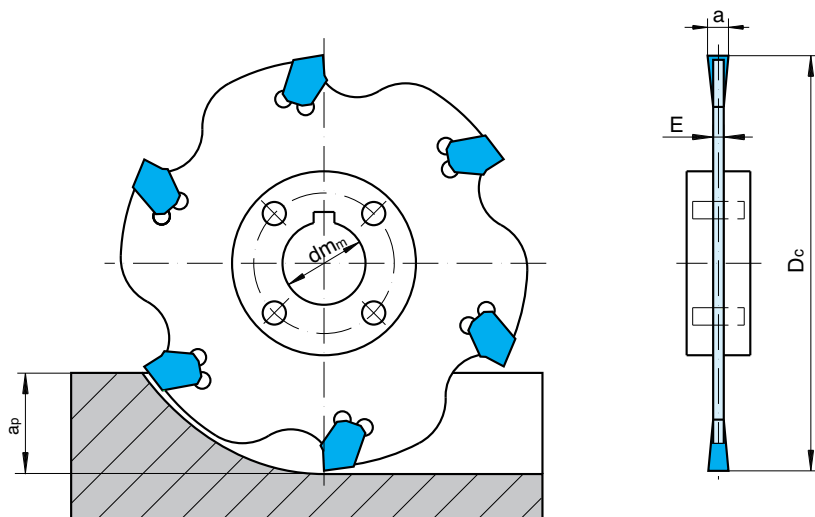

Frez tarczowy
Slitting cutter

	D_c (mm)	$d_{m\phi}$ (mm)	E (mm)	Ilość ostrzy No. of teeth	n_{max} obr/min	a_p (mm)	Płytki Insert	a (mm)	Zabierak Adaptor ring
NFTs 100-22-3	100	22	2,4	6	800	27	LFMX 3N	3,1	Z 22-46
NFTs 100-22-4	100	22	3,2	6	800	27	LFMX 4N	4,1	Z 22-46
NFTs 100-22-5	100	22	4	6	800	27	LFMX 5N	5,1	Z 22-46
NFTs 125-32-3	125	32	2,4	8	640	35	LFMX 3N	3,1	Z 32-55
NFTs 125-32-4	125	32	3,2	8	640	35	LFMX 4N	4,1	Z 32-55
NFTs 125-32-5	125	32	4	8	640	35	LFMX 5N	5,1	Z 32-55
NFTs 160-32-3	160	32	2,4	10	500	52	LFMX 3N	3,1	Z 32-55
NFTs 160-32-4	160	32	3,2	10	500	52	LFMX 4N	4,1	Z 32-55
NFTs 160-32-5	160	32	4	10	500	52	LFMX 5N	5,1	Z 32-55
NFTs 160-40-3	160	40	2,4	10	500	39	LFMX 3N	3,1	Z 40-80
NFTs 160-40-4	160	40	3,2	10	500	39	LFMX 4N	4,1	Z 40-80
NFTs 160-40-5	160	40	4	10	500	39	LFMX 5N	5,1	Z 40-80
NFTs 200-40-3	200	40	2,4	14	400	59	LFMX 3N	3,1	Z 40-80
NFTs 200-40-4	200	40	3,2	14	400	59	LFMX 4N	4,1	Z 40-80
NFTs 200-40-5	200	40	4	14	400	59	LFMX 5N	5,1	Z 40-80
NFTs 250-40-3	250	40	2,4	18	320	84	LFMX 3N	3,1	Z 40-80
NFTs 250-40-4	250	40	3,2	18	320	84	LFMX 4N	4,1	Z 40-80
NFTs 250-40-5	250	40	4	18	320	84	LFMX 5N	5,1	Z 40-80
NFTs 315-40-4	315	40	3,2	22	250	117	LFMX 4N	4,1	Z 40-80
NFTs 315-40-5	315	40	4	22	250	117	LFMX 5N	5,1	Z 40-80

LFMX



Części zamienne
Spare parts

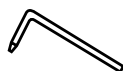

Klucz płytki
Insert key

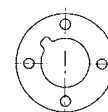

Zabierak
Adaptor ring

150.19-130

Z 22-46 / Z 32-55 / Z 40-80



